

Garlock Metallic Gaskets

Designed to withstand extremes



Garlock Metallic Gaskets

Garlock Metallic Gaskets, a division of Garlock, manufactures spiral wound, serrated metal, metal clad, solid metal and metal core gaskets at its facility in Houston, Texas. This facility is registered to ISO-9001.

In recent years, Garlock Metallic Gaskets has introduced some of the industry’s most innovative production methods and products. For example, the CONTROLLED DENSITY™ process for spiral wound gaskets ensures a high tightness level at a lower bolt stress. The TANDEM SEAL™ combines chemical resistance and fire safety in a single gasket. The Garlock EDGE® gasket seals at lower bolt stress while virtually eliminating the problem of inward buckling. Various metal gaskets are now available with THERMa-PUR® for high temperature applications. Garlock Metallic Gaskets is also known for excellence in material and product quality as well as its outstanding customer service.

This catalog is provided for customer information and convenience. However, Garlock applications engineers are also on hand to assist you with your application requirements and technical questions. Please give us a call at 1-800-448-6688. We are here to serve you.

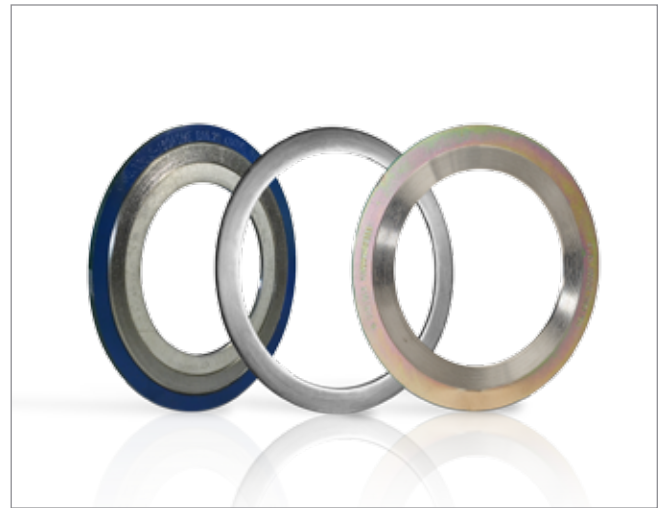

CONTROLLED DENSITY™, TANDEM SEAL™, THERMa-PUR®, STABIL-LOCK™ and G.E.T.™ are trademarks of Garlock
EDGE®, GRAPHONIC®, FLEXSEAL®, THERPHONIC®, and TEPHONIC® are registered trademarks of Garlock

CONTENTS

Metallic Gasket Styles

Gasket Selection.....	4
Spiral Wound Gaskets	5
The Garlock EDGE® Gasket	6
HEAT SHIELD™ Gasket	7
TANDEM SEAL™ Gasket.....	8
FLEXSEAL® Family	
RW, RWI, SW (For ASME flanges).....	9
MCR (For boiler manholes).....	10
HH (For boiler handholes).....	11
RW-RJ, RWI-RJ (For ring joint flanges)	12
LMF (For large male/female flanges).....	13
LTG (For large tongue and groove flanges).....	14
STG (For small tongue and groove flanges)	14
Low-Load.....	15
ULE (Ultra low Emissions).....	16
Metal-Clad Gasket Styles	18
Corrugated Metal Gaskets.....	20
GRAPHONIC®	20
TEPHONIC™	20
G.E.T.™	20
THERPHONIC®	20
Exchanger and Vessel Gaskets.....	21
Heat Exchanger Gasket Configurations	21
Garlock Kammprofile Gasket	22

Engineering Data

Factors Affecting Gasket Performance	23
Material Temperature Limits.....	24
Thickness and Tolerances.....	24
Flange Types.....	25
Recommended Flange Finish	26
Maximum Bore.....	27
Gasket Dimensions	28
Gasket Factors M and Y	37
Selection of Metals.....	38
Flange Rotation.....	39
Gasket Installation	40
Torque Tables.....	41
Troubleshooting Leaking Joints	46
Ordering Guide	47
Application Data Form	48
Conversions.....	49

Gasket Selection

SPRIAL WOUND GASKETS

One of the best all-around seals, the spiral wound gasket offers a low-cost solution that has the ability to handle temperature and pressure fluctuations. Multiple plies of metal and filler in the spiral create a barrier that reduces the possibility of leaks.

TEMPERATURE AND CHEMICAL CONSIDERATIONS

Be certain that the gasket you order is as resistant as possible to the media and temperature involved. Check the chemical compatibility of the metal as well as the filler material for the media to be sealed. As a general rule, the metal used in either the spiral winding or double-jacketed gasket should be similar to the flange material.

The compressibility of flexible graphite makes it an excellent filler material for metallic gaskets. Flexible graphite may be used in services with temperatures up to 850°F (450°C), though it should not be used with strong oxidizers such as nitric or sulfuric acid.

PTFE filler material provides excellent chemical resistance at temperatures below 500°F (260°C). In accordance with ASME B16.20, an inner ring is required when using conventional PTFE filler materials, in order to protect the winding from radial buckling.

See page 24 for the temperature limits of common metals and filler materials.

OPERATING PRESSURE

Operating pressures have a direct effect on the construction and selection of metallic gaskets. Higher pressures raise the potential for gasket blowout, while lower pressure applications require a gasket design that seals under lower bolt loads.

Garlock gaskets suitable for high pressure include:

- » Kammprofile gaskets
- » Spiral wound gaskets with inner ring
- » Solid metal gaskets

Low pressure gaskets include:

- » GRAPHONIC® gaskets
- » Garlock Kammprofile gaskets
- » The Garlock EDGE® gasket

OTHER METAL GASKETS

Garlock manufactures a wide variety of double-jacketed, spiral-wound, metal-clad and solid metal gaskets for heat exchanger and coker applications. GRAPHONIC® and Kammprofile gaskets are also available in heat exchanger configurations.

WARNING:

Properties/applications shown throughout this brochure are typical. Your specific application should not be undertaken without independent study and evaluation for suitability. For specific application recommendations consult Garlock. Failure to select the proper sealing products could result in property damage and/or serious personal injury.

Performance data published in this brochure has been developed from field testing, customer field reports and/or in-house testing.

While the utmost care has been used in compiling this brochure, we assume no responsibility for errors. Specifications subject to change without notice. This edition cancels all previous issues. Subject to change without notice.

Spiral Wound Gaskets

MANUFACTURED IN ACCORDANCE WITH ASME B16.20

Spiral wound gaskets—made with an alternating combination of formed metal wire and soft filler materials—form a very effective seal when compressed between two flanges. A v-shaped crown centered in the metal strip acts as a spring, giving gaskets greater resiliency under varying conditions. Filler and wire material can be changed to accommodate different chemical compatibility requirements. Fire safety can be assured by choosing flexible graphite as the filler material. If the load available to compress a gasket is limited, gasket construction and dimensions can be altered to provide an effective seal.

A spiral wound gasket may include a centering ring, an inner ring or both. The outer centering ring centers the gasket within the flange and acts as a compression limiter, while the inner ring provides additional radial strength. The inner ring also reduces flange erosion and protects the sealing element.

Resiliency and strength make spiral wound gaskets an ideal choice under a variety of conditions and applications. Widely used throughout refineries and chemical processing plants, spiral wound gaskets are also effective for power generation, pulp and paper, aerospace, and a variety of valve and specialty applications.

As set forth in ASME B16.20, all PTFE filled spiral wound gaskets will be supplied with inner rings. In addition, the following higher pressure class spirals will be supplied with inner rings for all filler material:

- » NPS 24 and larger 900#
- » NPS 12 and larger 1500#
- » NPS 4 and larger 2500#

Starting in May 2008, the metricated edition of this standard recommends the use of inner rings for all graphite filled spiral wound gaskets. However, these gaskets may be specified without inner rings by the purchaser. Both styles will still be stamped ASME B16.20 compliant on the outer guiding ring.

GASKET IDENTIFICATION MARKINGS REQUIRED BY ASME B16.20

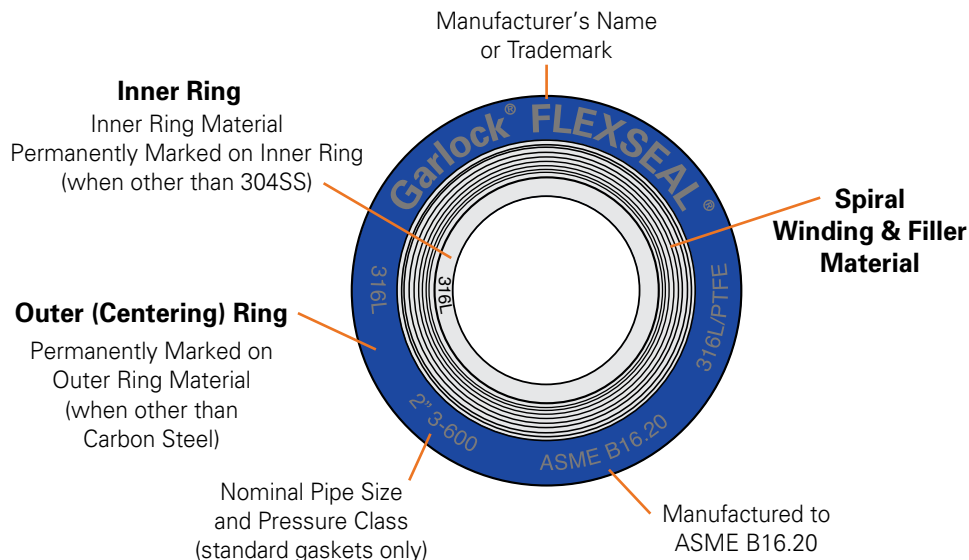

The Garlock EDGE®

BENEFITS

Requires lower seating stress

- » Seals at lower stress than conventional gaskets without an inner ring
- » Eliminates flange damage caused by overtightening
- » Relief ports allow tighter seal at lower loads

Eliminates radial buckling

- » STABL-LOCK™ inner wrap construction prevents sealing element from flowing into and contaminating process stream

Tightest seal

- » Modified guide ring ensures contact centered on raised face flange surfaces*

Multiple applications

- » Available in a dual flange (DF) design to accommodate both 150# and 300# flanges
- » Select from a wide variety of metallic and filler materials with a full range of temperature capabilities**
- » Also available in HEAT SHIELD™ configuration for high temp services above 850°F.

Seals with lower bolt loads

- » Relief tab design provides solid seating of centering ring face
- » Withstands bolt load loss caused by thermal cycling
- » Inner wrap construction eliminates radial buckling
- » Prevents catastrophic failure and potential damage to downstream equipment due to wire unraveling

COMPARE

The patented Garlock EDGE® spiral wound gasket is designed to reduce inward buckling



Standard spiral wound gasket shows excessive inward buckling

DUAL FLANGE (DF) DESIGN

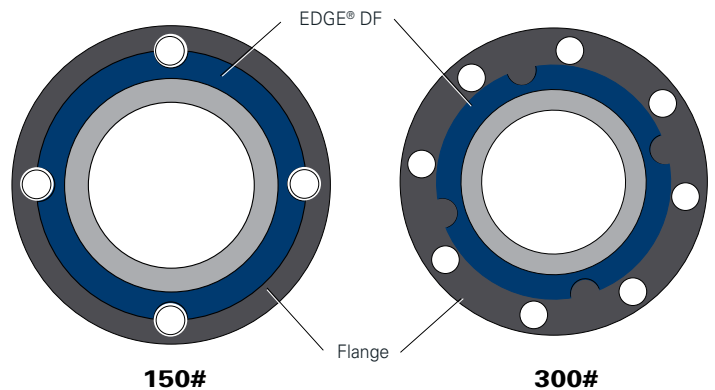

Gasket Style & Material	"M"	"Y" (psi)	Gb (psi)	"a"	Gs (psi)
Garlock EDGE® with 304 stainless and fledible graphite filler	2.00	5,000	793	0.4	0.31

* Not intended for use on slip-on and many light weight lap joint flanges.

** See chart on page 24.

HEAT SHIELD™ Gasket

The flexible graphite filled spiral wound gasket is widely used throughout chemical plants and refineries. Exceptional sealability and fire safety of this gasket make it superior to other types of spiral wound gaskets. It's ideal for thermal oxidizing environments and provides a good choice for plant steam drums, hydrocarbon cat crackers, hydrogen units and exhaust manifolds.

BENEFITS

- » Fire safe and rated to 1250°F (677°C)
- » Flexible graphite-filled spiral wound gasket has ID and OD filler plies of THERMa-PUR® or mica.
- » THERMa-PUR® or mica layers protect the flexible graphite center from thermal oxidizing atmospheres
- » Metal wire of the gasket can be made of a wide range of materials, depending upon the application

TYPICAL APPLICATIONS

- » Oxidizing environments
- » Power plant steam drums
- » Hydrocarbon processing catcrackers
- » Chemical plant Oleflex units and ammonium nitrate service
- » Hydrogen units, exhaust manifolds, and more.

CONSTRUCTION

- » Heat-resistant graphite filler
- » Available with heat- and oxidation-resistant THERMa-PUR® or pure mica filler
- » Spiral-wound wires of a choice of commercially available metals
- » Rings of any standard metal, including INCONEL®* X750

Gasket Style & Material	Gasket M Factor	Gasket Y Factor
Traditional spiral wound gasket 304SS and flexible graphite	3.00	10,000
Garlock CONTROLLED DENSITY™ spiral wound gasket	3.00	7,500

*Inconel is a registered trademark of Inco Alloys International, Inc.



SPECIFICATIONS

Temperature, Max.	1250°F (677°C)
Flange Class	150# to 600#
Pipe diameters	2" to 24", specials available

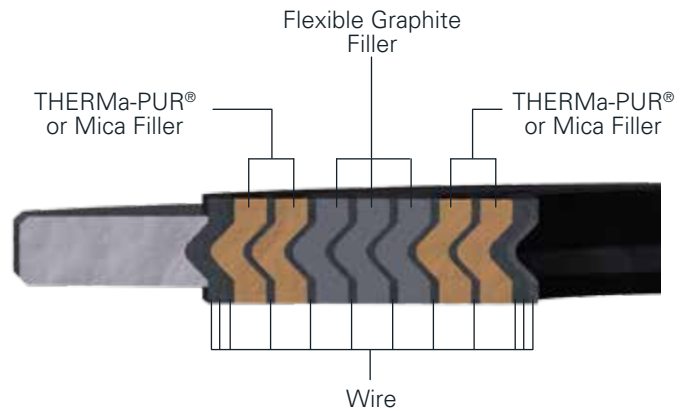

NOTE:

References made to particular applications are not a guarantee of acceptability of use for these services. Contact Garlock for additional details and to discuss your particular application.

TANDEM SEAL™

BENEFITS

Chemical-resistant and fire-safe

- » PTFE envelope withstands aggressive chemicals and corrosive media
- » Fire-safe—passed independent fire tests
- » Two sealing elements significantly reduce corrosion and bacterial contamination of flanges
- » Seals to the ID of the pipe bore - specify pipe schedule when ordering



SEAL COMPARISON

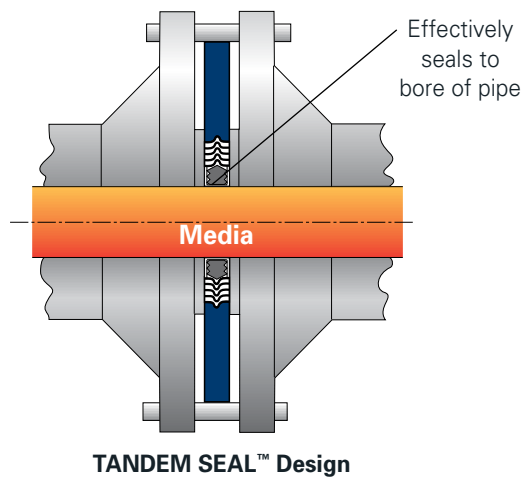
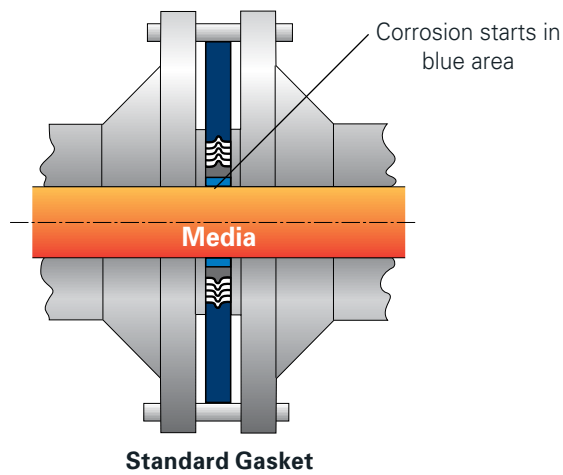

STANDARD CONSTRUCTION

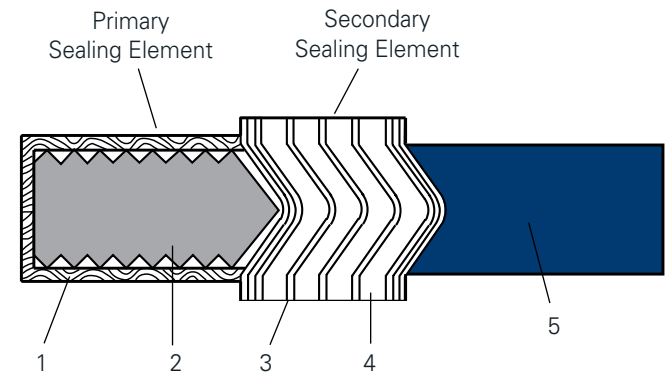

- | | |
|---------------------------|---------------------|
| 1. PTFE envelope | 4. Filler material |
| 2. Kammprofile inner ring | 5. Outer guide ring |
| 3. Metal windings | |

ALTERNATE CONSTRUCTION

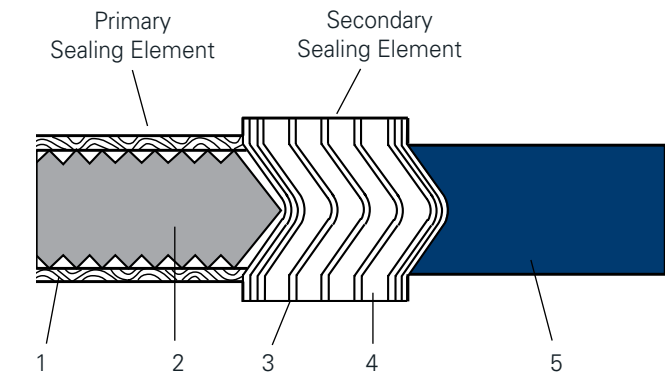

- | | |
|---|---------------------|
| 1. Flexible Graphite or Expanded Teflon® Facing | 3. Metal windings |
| 2. Kammprofile inner ring | 4. Filler material |
| | 5. Outer guide ring |

* Acid detecting paint also available

Patent No. 5511797

FLEXSEAL® RW, RWI and SW Gaskets

ADVANTAGES

- » Durable; easy installation and removal
- » Seals pressures to flange ratings, in accordance with ASME B16.5 & B16.47
- » Suitable for temperatures from cryogenic to 2,000°F (1,093°C)*
- » Guide ring simplifies centering of sealing element on the flange face
- » Designed solutions accommodate a variety of conditions by combining various metals and filler materials



STYLE RWI

- » Suitable for flat face and raised face flanges up to Class 2500#**
- » Recommended for all gaskets, mandated for use with PTFE fillers, and when mandated by ASME B16.20 as follows: NPS 24 and larger in Class 900#, NPS 12 and larger in Class 1500#, and NPS 4 and larger in Class 2500#.
- » Inner ring acts as compression limiter and protects sealing elements from process media attack

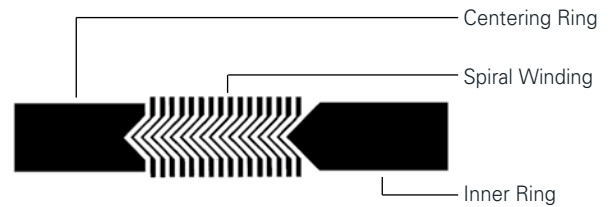

STYLE RW

- » General purpose gasket suitable for flat face and raised face flanges up to Class 2500#**
- » Centering ring accurately locates the gasket on the flange face, provides additional radial strength, and acts as a compression limiter
- » Spiral winding (sealing element) consists of preformed metal and soft filler material

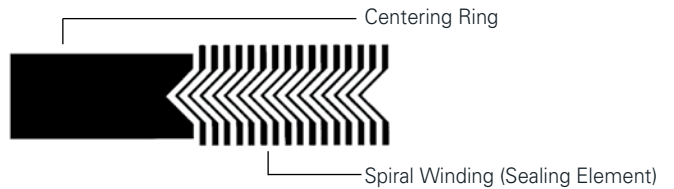

STYLE SW

- » Suitable for tongue and groove, male-female, or groove-to-flat face flanges†
- » Spiral winding only, containing preformed metal and soft filler material
- » Also available with inner rings—Style SWI

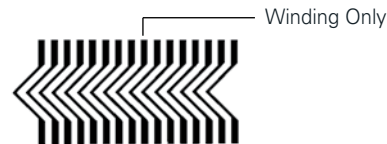

ORDERING INFORMATION

RW / RWI

When ordering specify:

- » Nominal pipe size or specific gasket dimensions
- » Pressure rating
- » Winding and filler materials
- » Centering and/or inner compression ring material

SW

When ordering, specify:

- » O.D. and I.D. dimensions (and tolerance, if other than standard - see page 24)
- » Thickness of gasket
- » Pressure rating
- » Winding and filler material
- » Inner ring material, if required (Style SWI)

NOTES:

For M & Y factors, see page 37

* Consult Garlock Engineering for material recommendations above 850° F (450°C)

** Depending on gasket size, an inner ring is recommended for applications above Class 600#, due to the high available bolt load. See also Note 1 on page 27 .

† This design does not have a compression limiter

FLEXSEAL® MCR Gasket

MCR GASKET (manhole cover with centering ring)

- » Centering ring accurately locates the gasket on the flange face, provides additional radial strength, and acts as a compression limiter
- » Spiral winding (sealing element) consists of preformed metal and soft filler material

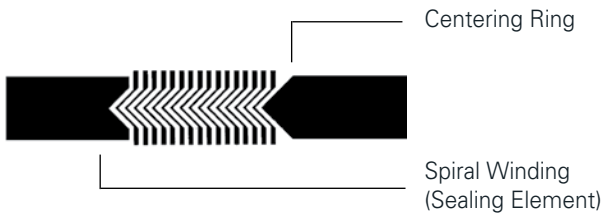

MCR CONFIGURATIONS

ROUND

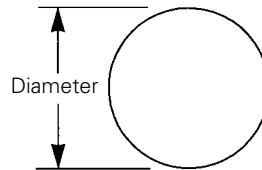

OBROUND

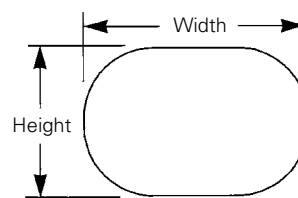

OVAL

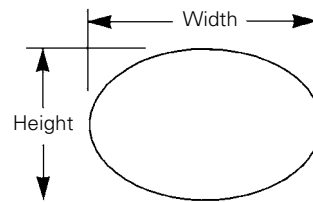

ORDERING INFORMATION

When ordering, specify:

- » Make and model of boiler and/or equipment if available (See chart page 11)
- » Gasket style and configuration
- » Dimensions of gasket (thickness, flange seating width, and shape)
- » Maximum operating pressure and temperature
- » Type of metal and filler materials
- » Available in .175" and .250" thickness

WARNING:

Properties/applications shown throughout this brochure are typical. Your specific application should not be undertaken without independent study and evaluation for suitability. For specific application recommendations consult Garlock. Failure to select the proper sealing products could result in property damage and/or serious personal injury.

Performance data published in this brochure has been developed from field testing, customer field reports and/or in-house testing.

While the utmost care has been used in compiling this brochure, we assume no responsibility for errors. Specifications subject to change without notice. This edition cancels all previous issues. Subject to change without notice.

NOTES:

1. For pitted and rough flange surfaces, specify a gasket thickness of 0.250".
2. Orders for special cover assemblies should be accompanied by a dimensional drawing showing the minimum width of seating surfaces and other essential dimensions.
3. Orders for non-standard gaskets should also include a sketch or drawing of the cover assembly with all dimensions shown.

FLEXSEAL[®] HH Gasket

FOR BOILER HANDHOLE AND TUBECAP ASSEMBLIES

- » Fits most standard boilers (specify maximum operating pressure when ordering)
- » Available in thicknesses of 0.125" (special), 0.175" (standard) and 0.250" (special—for pitted surfaces)

STYLE HH CONFIGURATIONS

ROUND

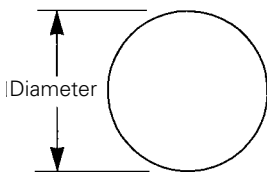

RECTANGLE

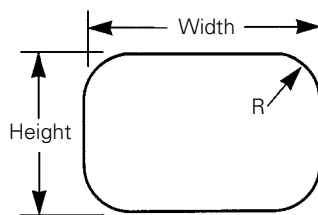

OBROUND

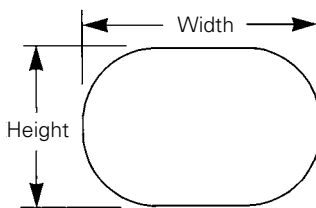

DIAMOND

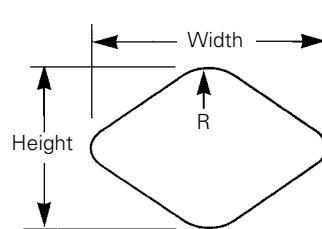

OVAL

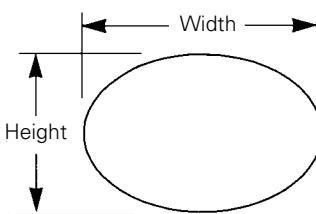

PEAR

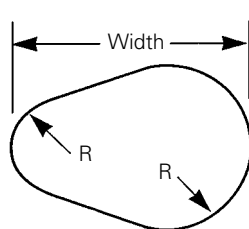

WARNING:

Properties/applications shown throughout this brochure are typical. Your specific application should not be undertaken without independent study and evaluation for suitability. For specific application recommendations consult Garlock. Failure to select the proper sealing products could result in property damage and/or serious personal injury.

Performance data published in this brochure has been developed from field testing, customer field reports and/or in-house testing.

While the utmost care has been used in compiling this brochure, we assume no responsibility for errors. Specifications subject to change without notice. This edition cancels all previous issues. Subject to change without notice.

BOILER GASKET DIMENSIONS

Manufacturer & Model No.	Shape	Nominal I.D. Dimensions (Inches)	Flange Width (Inches)
Babcock and Wilcox			
#40 (207)	Diamond	3-3/8 x 3-3/4	3/16
#48 (208)	Oval	3-3/16 x 4-3/4	7/32
#24 (211)	Oval	4-1/2 x 5-1/2	7/32
#47	Round	2-1/32	3/16
#70	Round	3-9/32	3/16
#28 (212)	Rectangle	4-13/16 x 5	7/32
Badenhausen (See Riley Stoker)			
Cleaver-Brooks	Obround	3-9/32 x 4-17/32	3/8
Combustion Engr.			
29N-L839	Diamond	3-3/8 x 4-1/4	1/4
4N-L740	Round	3-1/8	1/4
5N-L902	Round	3-5/8	1/4
Foster Wheeler			
2-3/4 (1003)	Obround	2-25/32 x 3-13/32	7/32
3-15/16 (1005)	Oval	4-3/16 x 5-3/16	5/16
Heine	Round	3-5/8	3/8
Keeler	Obround	3 x 4	3/8
Oilfield	Oval	3 x 4	3/8
	Oval	3-1/2 x 4-1/2	3/8
Riley Stoker W-C2	Obround	3-23/32 x 5-23/32	11/32
Springfield	Oval	3-17/32 x 4-17/32	5/16
Union	Oval	3 x 4	3/8
	Pear	4-1/4 x 5-1/4	3/8
Vogt	Oval	4-1/4 x 5-1/8	7/32 (new)
Wickes			
	Pear	4-1/8 x 5-1/8	9/32
D2300	Oval	3 x 4	5/16
D2301	Oval	3-1/2 x 4-1/2	5/16

ORDERING INFORMATION

When ordering, specify:

- » Make and model of boiler and/or equipment, if available
- » Gasket style and configuration
- » Dimensions of gasket (thickness, flange seating width, and shape)
- » Maximum operating pressure and temperature
- » Type of metal and filler materials

FLEXSEAL® RW-RJ, RWI-RJ Gaskets

FOR REPLACEMENT OF RING JOINT GASKETS

- » Ideal replacement for solid metal oval or octagonal API ring joint gaskets (RTJ)
- » Saves cost of flange replacement when gasket groove is badly worn
- » Fast and easy installation—requires only a 3/16" flange separation (ring joint gasket may require as much as 3/4")
- » Wide variety of metal and filler materials have a full range of temperature and pressure capabilities

Dimensions for weld neck type flanges having a pipe bore equal to that of schedule 40 pipe and heavier, but not for slip-on flanges; exceptions noted below.

Nominal Pipe Size (Inches)	150#			300#			400#		
	I.D.	Gasket O.D.	Ring O.D.	I.D.	Gasket O.D.	Ring O.D.	I.D.	Gasket O.D.	Ring O.D.
1/2	—	—	—	9/16	1-1/16	2-1/8	9/16	1-1/16	2-1/8
3/4	—	—	—	13/16	1-5/16	2-5/8	13/16	1-5/16	2-5/8
1	1-1/8*	1-5/8*	2-5/8*	1-1/16	1-5/8	2-7/8	1-1/16	1-5/8	2-7/8
1-1/4	1-3/8*	1-7/8*	3*	1-5/16	2	3-1/4	1-5/16	2	3-1/4
1-1/2	1-5/8*	2-1/4*	3-3/8*	1-9/16	2-3/8	3-3/4	1-9/16	2-3/8	3-3/4
2	2-1/8*	2-7/8*	4-1/8*	2-1/8	2-3/4	4-3/8	2-1/8	2-3/4	4-3/8
2-1/2	2-3/4*	3-5/16*	4-7/8*	2-3/4	3-5/16	5-1/8	2-3/4	3-5/16	5-1/8
3	3-5/16*	3-15/16*	5-3/8*	3-5/16	3-15/16	5-7/8	3-5/16	3-15/16	5-7/8
4	4-5/16*	5-3/16*	6-7/8*	4-5/16	5-3/16	7-1/8	4-5/16	5-3/16	7
5	5-5/16*	6-3/16*	7-3/4*	5-5/16	6-7/16	8-1/2	5-5/16	6-7/16	8-3/8
6	6-5/16*	7-3/16*	8-3/4*	6-7/16	7-5/8	9-7/8	6-7/16	7-5/8	9-3/4
8	8-1/4*	9-3/16*	11*	8-1/4	9-15/16	12-1/8	8-1/4	9-15/16	12
10	10-5/16*	11-7/16*	13-3/8*	10-5/16	12	14-1/4	10-5/16	12	14-1/8
12	12-3/16*	13-9/16*	16-1/8*	12-7/8†	14-1/4†	16-5/8†	12-7/8†	14-1/4†	16-1/2†
14	13-7/16*	14-15/16*	17-3/4*	14-1/4†	15-3/4†	19-1/8†	14-1/4†	15-3/4†	19†
16	15-5/16*	16-15/16*	20-1/4*	16-1/4†	17-3/4†	21-1/4†	16-1/4†	17-3/4†	21-1/8†
18	17-1/4*	19*	21-5/8*	18-1/4†	20-1/4†	23-1/2†	18-1/4†	20-1/4†	23-3/8†
20	19-1/8*	21-1/8	20-1/4†	* 23-7/8*	22-3/16†	25-3/4	22-3/16†	† 20-1/4†	25-1/2†
24	23*	25-1/4*	28-1/4*	24-1/4†	26-5/16†	30-1/2†	24-1/4†	26-5/16†	30-1/4†

† Suitable for slip-on and weld neck type flanges

* 150# - 400#: for weld neck type flanges having a pipe bore equal to that of schedule 40 pipe. Not for slip-on flanges.

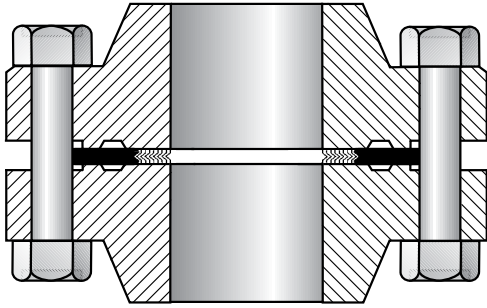

Dimensions for weld neck type flanges having a pipe bore equal to that of schedule 40 pipe and heavier, but not for slip-on flanges; exceptions noted below.

Nominal Pipe Size (Inches)	600#			900#			1500#		
	I.D.	Gasket O.D.	Ring O.D.	I.D.	Gasket O.D.	Ring O.D.	I.D.	Gasket O.D.	Ring O.D.
1/2	9/16	1-1/16	2-1/8	9/16*	1-1/16*	2-1/2*	9/16*	1-1/16*	2-1/2*
3/4	13/16	1-5/16	2-5/8	13/16*	1-3/8*	2-3/4*	13/16*	1-3/8*	2-3/4*
1	1-1/16	1-5/8	2-7/8	1-1/16*	1-5/8*	3-1/8*	1-1/16*	1-5/8*	3-1/8*
1-1/4	1-5/16	2	3-1/4	1-5/16*	2*	3-1/2*	1-5/16*	2*	3-1/2*
1-1/2	1-9/16	2-3/8	3-3/4	1-9/16*	2-3/8*	3-7/8*	1-9/16*	2-3/8*	3-7/8*
2	2-1/8	2-3/4	4-3/8	2-1/4*	3-1/4*	5-5/8*	2-1/4*	3-1/4*	5-5/8*
2-1/2	2-3/4	3-5/16	5-1/8	2-9/16*	3-5/8*	6-1/2*	2-9/16*	3-5/8*	6-1/2*
3	3-5/16	3-15/16	5-7/8	3-3/16*	4-3/16*	6-5/8*	3-3/16*	4-11/16*	6-7/8*
4	4-5/16	5-3/16	7-5/8	4-1/16*	5-3/16*	8-1/8*	4-1/16*	5-11/16*	8-1/4*
5	5-5/16	6-7/16	9-1/2	5-5/16	6-7/16	9-3/4	5-1/16*	6-15/16*	10*
6	6-7/16	7-5/8	10-1/2	6-5/16	7-5/8	11-3/8	6*	7-9/16*	11-1/8*
8	8-1/4	9-15/16	12-5/8	8-1/4	9-15/16	14-1/8	7-7/8*	9-3/4*	13-7/8*
10	10-5/16	12	15-3/4	10-5/16	12	17-1/8	9-13/16*	11-7/8*	17-1/8*
12	12-7/8 [†]	14-1/4 [†]	18 [†]	12-7/8	14-1/4	19-5/8	11-15/16*	13-13/16*	20-1/2*
14	14-1/4 [†]	15-3/4 [†]	19-3/8 [†]	13-13/16	15-9/16	20-1/2	13-7/16	15-3/16	22-3/4
16	16-1/4 [†]	17-3/4 [†]	22-1/4 [†]	15-9/16	17-9/16	22-5/8	15	17	25-1/4
18	18-1/4 [†]	20-1/4 [†]	24-1/8 [†]	17-11/16	19-15/16	25-1/8	17-1/4	19-1/2	27-3/4
20	20-1/4 [†]	22-3/16 [†]	26-7/8 [†]	19-11/16	21-15/16	27-1/2	19-3/16	21-7/16	29-3/4
24	24-1/4 [†]	26-5/16 [†]	31-1/8 [†]	23-3/16	25-15/16	33	23	25-1/2	35-1/2

[†] Suitable for slip-on and weld neck type flanges
 * 600# - 1500#: for schedule 80 pipe and heavier.

FLEXSEAL® LMF, LTG and STG Gaskets

FOR MALE-FEMALE, TONGUE AND GROOVE FLANGES

- » Spiral winding of preformed metal and soft filler material—for use where no space is provided for a compression guide ring
- » Inner Diameter of windings is reinforced with several plies of metal without filler to give greater stability
- » Style LMF - large male-female flanges
Style LTG - large tongue and groove flanges
Style STG - small tongue and groove flanges

APPLICATIONS

- » Valves
- » Heat exchangers
- » Pumps
- » Vessels
- » Flanges

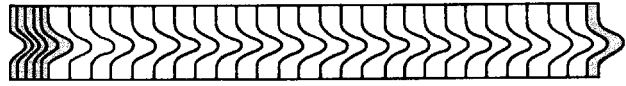

Cross Sectional View of Winding

ORDERING INFORMATION

When ordering, specify:

- » Nominal pipe size
- » Pressure rating
- » Winding materials (304 SS is standard, filler material must be specified)
- » Thickness of winding (0.125" is standard)

STYLE LMF GASKET DIMENSIONS

Nominal Pipe Size (Inches)	150# - 1500#		2500#	
	I.D. (Inches)	O.D. (Inches)	I.D. (Inches)	O.D. (Inches)
1/2	1	1-3/8	13/16	1-3/8
3/4	1-5/16	1-11/16	1-1/16	1-11/16
1	1-1/2	2	1-1/4	2
1-1/4	1-7/8	2-1/2	1-5/8	2-1/2
1-1/2	2-1/8	2-7/8	1-7/8	2-7/8
2	2-7/8	3-5/8	2-3/8	3-5/8
2-1/2	3-3/8	4-1/8	3	4-1/8
3	4-1/4	5	3-3/4	5
3-1/2	4-3/4	5-1/2	—	—
4	5-3/16	6-3/16	4-3/4	6-3/16
5	6-5/16	7-5/16	5-3/4	7-5/16
6	7-1/2	8-1/2	6-3/4	8-1/2
8	9-3/8	10-5/8	8-3/4	10-5/8
10	11-1/4	12-3/4	10-3/4	12-3/4
12	13-1/2	15	13	15
14	14-3/4	16-1/4	—	—
16	17	18-1/2	—	—
18	19-1/4	21	—	—
20	21	23	—	—
24	25-1/4	27-1/4	—	—

STYLE LTG GASKET DIMENSIONS

Nominal Pipe Size (Inches)	150# - 1500#	
	I.D. (Inches)	O.D. (Inches)
1/2	1	1-3/8
3/4	1-5/16	1-11/16
1	1-1/2	2
1-1/4	1-7/8	2-1/2
1-1/2	2-1/8	2-7/8
2	2-7/8	3-5/8
2-1/2	3-3/8	4-1/8
3	4-1/4	5
3-1/2	4-3/4	5-1/2
4	5-3/16	6-3/16
5	6-5/16	7-5/16
6	7-1/2	8-1/2
8	9-3/8	10-5/8
10	11-1/4	12-3/4
12	13-1/2	15
14	14-3/4	16-1/4
16	17	18-1/2
18	19-1/4	21
20	21	23
24	25-1/4	27-1/4

STYLE STG GASKET DIMENSIONS

Nominal Pipe Size (Inches)	150# - 1500#	
	I.D. (Inches)	O.D. (Inches)
1/2	1	1-3/8
3/4	1-5/16	1-11/16
1	1-1/2	1-7/8
1-1/4	1-7/8	2-1/4
1-1/2	2-1/8	2-1/2
2	2-7/8	3-1/4
2-1/2	3-3/8	3-3/4
3	4-1/4	4-5/8
3-1/2	4-3/4	5-1/8
4	5-3/16	5-11/16
5	6-5/16	6-13/16
6	7-1/2	8
8	9-3/8	10
10	11-1/4	12
12	13-1/2	14-1/4
14	14-3/4	15-1/2
16	16-3/4	17-5/8
18	19-1/4	20-1/8
20	21	22
24	25-1/4	26-1/4

WARNING:

Properties/applications shown throughout this brochure are typical. Your specific application should not be undertaken without independent study and evaluation for suitability. For specific application recommendations consult Garlock. Failure to select the proper sealing products could result in property damage and/or serious personal injury.

Performance data published in this brochure has been developed from field testing, customer field reports and/or in-house testing.

While the utmost care has been used in compiling this brochure, we assume no responsibility for errors. Specifications subject to change without notice. This edition cancels all previous issues. Subject to change without notice.

FLEXSEAL® Low-Load Gasket

Garlock Low-Load spiral wound gaskets provide the superior sealing capabilities of a standard spiral wound gasket for flange connections with a low available bolt load. Gaskets are manufactured using a controlled manufacturing process to ensure consistent winding density across the entire sealing surface of the gasket.

SPECIFICATIONS

Spiral Winding	Choice of Metals
Filler Material	Choice of Fillers
Configurations	<ul style="list-style-type: none"> » RW-LL (outer ring spiral wound) » RWI-LL (outer & inner ring spiral wound) » SW-LL (winding only) » SWI-LL (winding with inner ring)
Flange types	Flat or raised face
Sizes	All
Pressure Classes	ANSI 150#-2500#
Temperature, Max.	To 1,200°F (650°C)
Gasket Factor "M"	3.00
Gasket Factor "Y"	5,000 psi

ADVANTAGE - GARLOCK'S FLEXSEAL® SPIRAL WOUND GASKETS STYLE CD+™LL

Meeting today's and tomorrow's even more stringent fugitive emissions standards requires the spiral wound gasket work in concert with all components of the flange connection, including flange connections with low available bolt loads. Garlock's CD+™LL gasket allows the use of standard spiral wound components by controlling the filler density to achieve a low compression gasket.

Gasket Style and Material	Gasket Factor "M"	Gasket Factor "Y" (psi)
Traditional spiral wound gasket — 304 SS and flexible graphite per ASME B16.20	3.00	10,000
Garlock's FLEXSEAL® Spiral Wound Gaskets Style CD+™ Standard — 304 SS and flexible graphite	3.00	7,500
Garlock's FLEXSEAL® Spiral Wound Gaskets Style CD+™LL Standard — 304 SS and flexible graphite	3.00	5,000

This table demonstrates the ability of the new Controlled Density+ (CD+) technology to produce a gasket with low compression characteristics. Garlock FLEXSEAL® spiral wound gaskets are capable of solving the most demanding spiral wound applications including weak flange installations.



VALUE & BENEFITS

- » Compensates for weak flange designs enhancing plant and personnel safety
- » Ensures bolt stresses do not exceed 25,000 psi for compliance with ASME 31.3 and PV and B codes
- » No unsupported exposed filler for ease of handling and installation
- » High tightness level achieved with minimal compressive load
- » Exceptional blow out resistance enhancing personnel safety
- » Available in wide range of spiral wound designs and materials of construction
- » Complies with ALL ASME B16.20 dimensions
- » Available in standard spiral wound gasket thicknesses (.125", .175", .250" and .285")

IDEAL FOR

- » Hydrocarbon processing & refining
- » Petrochemical processing
- » Chemical processing
- » Power generation
- » Pulp & paper
- » Oil & Gas production

Garlock FLEXSEAL® ULE (Ultra Low Emissions) Spiral Wound

Spiral wound gasket for stringent future emission requirements

Garlock has expanded their ULE (Ultra Low Emissions) family of products to include a spiral wound gasket. The FLEXSEAL® ULE is designed for use where leakage control is critical and the aggressive application requires a spiral wound design. It's manufactured using high performance graphite, and offers maximum protection against oxidation. The standard design includes an inner ring and outer ring, as well as preformed metal wire to enhance compressability and sealability. The FLEXSEAL® ULE spiral wound is another product born from Garlock's customer driven innovation.



VALUES AND BENEFITS

- » API 6FB
 - › Average leak rate recorded of 1.4 ml/min
- » Low Emissions (CFET)
 - › Provides average leakage rates of 10 PPM (parts per million)
- » Oxidation Resistance
 - › Offers maximum protection against oxidation for greater reliability and longer service life
 - › No aging or fatigue under dynamic load, even at elevated temperatures
- » Manufacturability
 - › Available in standard lead-time

CONFIGURATIONS

- » Available in
 - › Standard Flexseal Spiral Wound configurations: RW/ RWI/SW/SWI
 - › Materials and dimensions per ASME B16.20
 - › Materials available include various series 300 stainless, Hastelloy®, Inconel®** and titanium, custom materials are also available

IDEAL FOR

- » Thermal Cycling - Compressibility and recovery of high performance graphite combined with custom winding technology and processes that provides excellent chemical resistance and performance operating uncompromised in a wide temperature range
- » Industries where stringent fugitive emission requirements are found
- » Pressurized process equipment with evaporated sources, such as waste water treatment and storage tanks.

*Hastelloy is a registered trademark of Haynes International, Inc.

**Inconel is a registered trademark of Inco Alloys International, Inc.

According to API 641 the acceptable industry limit of leakage is 100ppm.

STANDARD GASKET

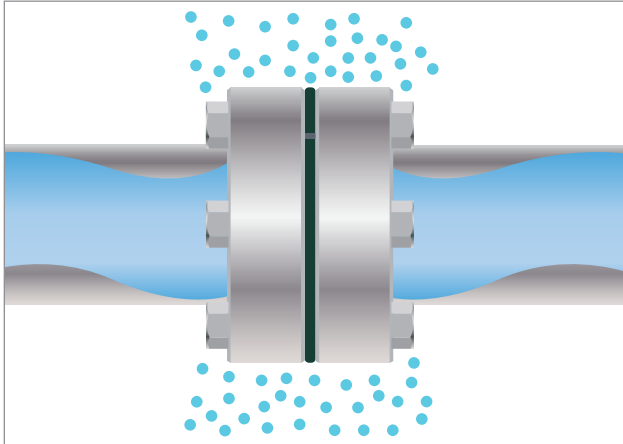

A standard spiral wound gasket can experience leak rates of up to 600ppm, 6 times greater than the standard set by API 641.

GARLOCK FLEXSEAL® ULE

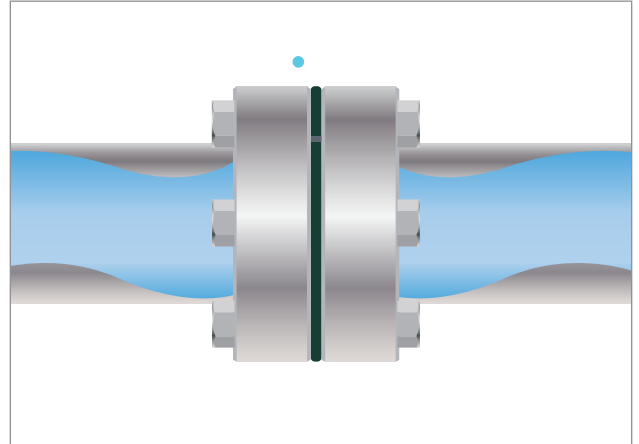

The Garlock FLEXSEAL® ULE spiral wound gasket is well under the new standard set by the API 641 regulation.

TORQUE TABLES

NPS	150#				300#				600#				900#				1500#				2500#			
	# of bolts	bolt size (in.)	min. torque (ft. lbs)	preferred torque (ft. lbs)	# of bolts	bolt size (in.)	min. torque (ft. lbs)	preferred torque (ft. lbs)	# of bolts	bolt size (in.)	min. torque (ft. lbs)	preferred torque (ft. lbs)	# of bolts	bolt size (in.)	min. torque (ft. lbs)	preferred torque (ft. lbs)	# of bolts	bolt size (in.)	min. torque (ft. lbs)	preferred torque (ft. lbs)	# of bolts	bolt size (in.)	min. torque (ft. lbs)	preferred torque (ft. lbs)
½	4	0.50	16	32	4	0.50	16	38	4	0.50	16	38	4	0.75	22	47	4	0.75	22	47	4	0.75	22	47
¾	4	0.50	22	44	4	0.63	28	63	4	0.63	28	63	4	0.75	31	70	4	0.75	31	70	4	0.75	31	70
1	4	0.50	30	63	4	0.63	38	89	4	0.63	38	89	4	0.88	49	117	4	0.88	49	117	4	0.88	49	117
1½	4	0.50	47	76	4	0.75	66	147	4	0.75	66	147	4	1.00	89	283	4	1.00	118	295	4	1.13	129	345
2	4	0.63	74	158	8	0.63	37	89	8	0.63	37	89	8	0.88	48	188	8	0.88	76	205	8	1.00	88	239
2½	4	0.63	87	158	8	0.75	48	118	8	0.75	48	118	8	1.00	65	286	8	1.00	108	298	8	1.13	119	349
3	4	0.63	120	158	8	0.75	71	165	8	0.75	71	165	8	0.88	106	291	8	1.13	150	403	8	1.25	166	515
4	8	0.63	92	146	8	0.75	103	256	8	0.88	149	378	8	1.13	191	523	8	1.25	231	690	8	1.50	245	760
5	8	0.75	124	236	8	0.75	124	265	8	1.00	221	563	8	1.25	268	665	8	1.50	323	946	8	1.75	430	1467
6	8	0.75	178	265	12	0.75	118	236	12	1.00	202	558	12	1.13	221	605	12	1.38	289	856	8	2.00	611	2074
8	8	0.75	200	265	12	0.88	194	378	12	1.13	307	809	12	1.38	333	967	12	1.63	432	1375	12	2.00	548	2081
10	12	0.88	236	407	16	1.00	206	499	16	1.25	346	969	16	1.38	306	960	12	1.88	754	2500	12	2.50	831	3353
12	12	0.88	320	407	16	1.13	309	722	20	1.25	365	969	20	1.38	368	1135	16	2.00	647	2323	12	2.75	1326	5404
14	12	1.00	408	623	20	1.13	269	578	20	1.38	408	1,070	20	1.50	388	1291	16	2.25	684	2725				
16	16	1.00	421	563	20	1.25	399	817	20	1.50	514	1,306	20	1.63	514	1692	16	2.50	1141	4346				
18	16	1.13	649	867	24	1.25	478	1,012	20	1.63	757	2,135	20	1.88	991	3194	16	2.75	1606	6140				
20	20	1.13	572	867	24	1.25	526	1,012	24	1.63	695	2,121	20	2.00	934	3152	16	3.00	1921	7732				
24	20	1.25	820	1,292	24	1.50	723	1,329	24	1.88	1,103	3,241	20	2.50	1382	5085	16	3.50	3,100	12,225				

Based on ASTM A193 B7 bolts

Metal-Clad Gaskets

GASKET STYLES

Style 600 - Corrugated Solid Metal

A plain, all-metal corrugated gasket for use in applications where facing materials are not acceptable.

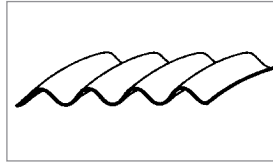

Style 624 - Single-Jacketed Overlap

Construction of this gasket offers more filler protection than the standard single-jacketed design. Although constructed like a single-jacketed gasket, it has the added benefit of totally encasing the filler material.

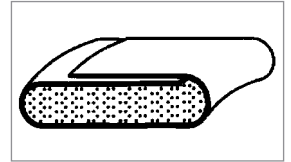

Style 606 - Solid Metal with Facing Graphite Covering

A solid metal gasket covered with a layer of soft facing material. This covering layer seals at a low load and fills voids and imperfections in the flange.

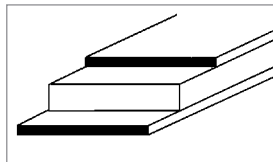

Style 626 - Double-Jacketed Corrugated

Concentric corrugated sealing element totally encapsulates the soft filler material. The corrugations give improved resilience in applications where thermocycling is a problem.

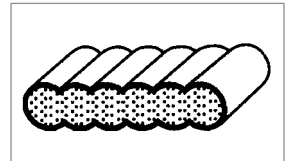

Style 620 - Single-Jacketed

Generally used where the radial dimensions of the equipment sealing surfaces only allow space for a narrow width seal. Single-jacketed gaskets are constructed as shown. The metal jacket reinforces the soft sealing material.

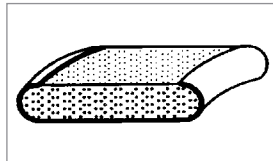

Style 627 - Double Shell

The double shell on this gasket allows greater hoop strength and rigidity with the addition of a completely overlapping inner seal. This gasket will withstand higher compressive loads common in high pressure applications.

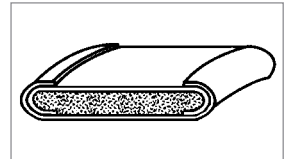

Style 623 - Double-Jacketed

The double-jacketed gasket has good compressibility and resilience and is the most popular metal-clad gasket manufactured.

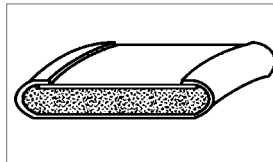

Style 629 - Double-Jacketed Corrugated with Corrugated Metal Filler

The metal filler in Style 629 has greater resilience to problems resulting from thermocycling. The temperature limits of this gasket are governed only by the metal selected.



Style 631 - Two-Piece French-Type

Garlock Style 631 is ideal for narrow circular applications that require a positive unbroken metal gasket line across the full width of the flange. The filler is exposed on the OD. This gasket is also available in one, two, and three-piece constructions.

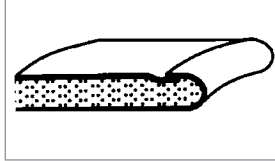

Style 635 - Selected Metal and CERAFELT®

This gasket is designed to be used in lightweight flanges. The thick compressible layer of CERAFELT® is shielded on the ID with a metallic barrier. Style 635 is commonly used in applications with very hot gases and low pressures.

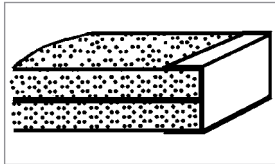

Style 640 - Solid Metal

This gasket offers extremely tight sealing, high mechanical strength, and good resistance to temperature, corrosion and pressure. Bolting stress and flange surface finish are key to the performance of this design.

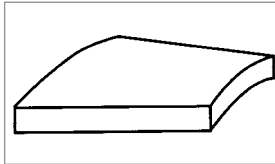

Style 641A - Solid Metal KAMMPROFILE

Profile gaskets combine the desirable qualities of a solid metal gasket with the advantages of a reduced area of contact, thereby reducing the bolt stress required to effect a seal. This gasket has the same advantages of strength, heat conductivity, and resistance to temperature, pressure and corrosion as Garlock Style 640.

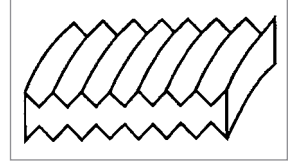

Style 642 - KAMMPROFILE with facing

Ideal for weaker flanges needing a seal under low stress. The solid metal arc resists cold flow, overcompression and blowout. Style 642's capability allows it to seal under compression, filling seating surface imperfections to form a tight connection.

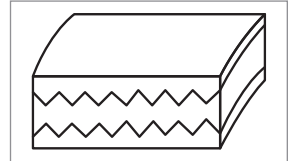

Styles 644 and 645 - Single- and Double - Jacketed Profile

Metal-jacketed profile gaskets employ the same principle of reduced contact area while protecting the flange faces from damage due to scoring. This gasket can be manufactured in one of two designs - either single-jacketed (Style 644) or double-jacketed (Style 645).

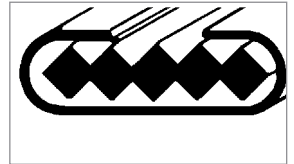

CERAFELT® is a registered trademark of Thermal Ceramics.

WARNING:

Properties/applications shown throughout this brochure are typical. Your specific application should not be undertaken without independent study and evaluation for suitability. For specific application recommendations consult Garlock. Failure to select the proper sealing products could result in property damage and/or serious personal injury. Performance data published in this brochure has been developed from field testing, customer field reports and/or in-house testing.

While the utmost care has been used in compiling this brochure, we assume no responsibility for errors. Specifications subject to change without notice. This edition cancels all previous issues. Subject to change without notice.

Corrugated Metal Gaskets

The superior technology of the corrugated family of gaskets ensures excellent sealing performance and reliability, even in the most difficult applications. Each of the four styles combines a corrugated metal core with a compressible sealing element of various materials, for resistance to a wide range of harsh conditions, including extreme temperature, corrosive chemicals, and thermal cycling.

APPLICATIONS

- » Valves
- » Pumps
- » Flanges
- » Heat exchangers
- » Vessels

GRAPHONIC® GASKET (STYLE 603)

With flexible graphite sealing element

- » Accommodates a wide range of temperatures
- » Seals effectively during thermal cycling
- » Fire safe—passed API 6FB fire tests
- » Chemically resistant
- » Long service life

TEPHONIC® GASKET (STYLE 604)

With ePTFE sealing element

- » Chemically inert
- » Forms a tight seal under low bolt load
- » Conforms to minor sealing surface imperfections
- » Withstands temperatures to 500°F (260°C)

G.E.T.™ GASKET (STYLE 607)

With graphite and ePTFE sealing element

- » Combines fire safety with chemical resistance
- » Conforms to minor sealing surface imperfections
- » Rigid yet compressible

ENGINEERING DATA

	GRAPHONIC®	TEPHONIC® and G.E.T.™	THERPHONIC™
Temperature,			
Minimum:	-400°F (-240°C)	-400°F (-240°C)	
Max. in atmosphere:	850°F (454°C)	500°F (260°C)	
Max. in steam:	1,200°F (650°C)	500°F (260°C)	
Max. continuous:	850°F (454°C)	500°F (260°C)	
Pressure, max.:	1,000 psig (70 bar)		
P x T, max.	700,000		
1/16" thickness:	(25,000)†		
1/8" thickness:	400,000	---	
	(13,500)	250,000 (8,500)	

† P x T max. = psig x °F (bar x °C)

NOTE:

When approaching maximum temperatures, consult the Garlock Engineering Department



THERPHONIC™ GASKET (613)

With THERMa-PUR® sealing element

- » Improved resistance to oxidizing media
- » Withstands temperatures to 1800°F (982°C)
- » Resists water and provides electrical isolation reducing the possibility of corrosion between flanges of dissimilar metals

CONSTRUCTION

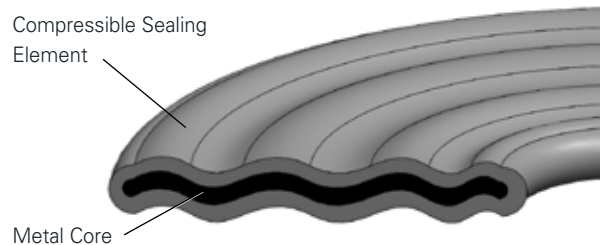

SEALING ELEMENTS

- » Flexible graphite
- » ePTFE
- » Combination graphite and ePTFE
- » THERMa-PUR®

STANDARD METALS

- » 316L Stainless
- » 304 Stainless
- » Carbon steel
- » INCONEL® 600
- » INCONEL® 625
- » INCOLOY® 800
- » INCOLOY® 825
- » HASTELLOY® C276
- » MONEL® 400

INCONEL® is a registered trademark of Inco Alloys International, Inc.
 INCOLOY® is a registered trademark of Inco Alloys International, Inc.
 HASTELLOY® is a registered trademark of Haynes International.
 MONEL® is a registered trademark of International Nickel.

Exchanger and Vessel Gaskets

Garlock manufactures a wide variety of solid metal, metal clad, and metal core gaskets. Among the most requested styles are double-jacketed gaskets, Kammprofile, corrugated gaskets, and solid metal gaskets, all available in a choice of metals and filler materials.

Custom configurations of heat exchanger gaskets are also available. Spiral windings can be designed with or without partitions welded to the winding, or inner and outer rings with welded partitions. Contact Garlock for all of your heat exchanger and vessel gasket needs.



TOLERANCES

Gasket Outside Diameter	Inside Diameter Tolerance	Outside Diameter Tolerance
Up to 36"	+1/16" / -0	+0 / -1/16"
36" and above	+1/8" / -0	+0 / -1/8"

Thickness: ±1/32" Radii: ±1/16"
 Rib Width: ±1/64" Rib Location: ±1/16"

GASKET WIDTHS

Gasket Diameter	Minimum Width (Gasket & Ribs)	Maximum Width
Up to 12"	3/16"	*
Over 12"	1/4"	*

* **NOTE:** There is no maximum width for heat exchanger gaskets.

GARLOCK HEAT EXCHANGER GASKET CONFIGURATIONS

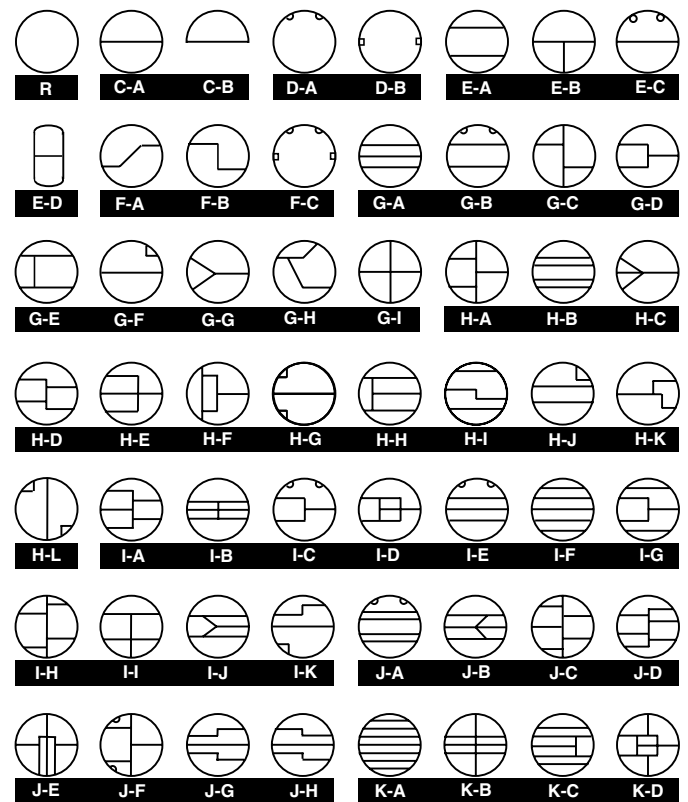

Garlock Kammprofile™ Gasket

BENEFITS

- » Accommodates standard ASME flanges as well as weaker and non-circular flanges
- » Seals less-than-perfect flanges
- » Handles pressures from vacuum to Class 2500#
- » Performance replacement for jacketed heat exchanger gaskets
- » Fire safe—passed API 6FB fire tests
- » Available with THERMa-PUR® facing

APPLICATIONS

- » Valves
- » Pumps
- » Flanges
- » Heat exchangers
- » Vessels

SERRATED SOLID METAL CORE



- » Solid metal core resists cold flow, overcompression and blowout
- » Rigid core provides exceptional stability, even in large sizes, and facilitates handling and installation
- » Available in wide variety of metals

SOFT, DEFORMABLE SEALING MATERIAL

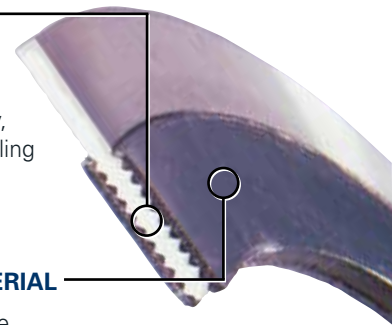
- » Under compression, fills seating surface imperfections to form a tight connection
- » Seals under low stress—ideal for weaker flanges
- » Withstands extreme fluctuations in temperatures and pressures



STYLE SELECTION GUIDE

Garlock Kammprofile™ Styles	Centering Ring		Flange			
	Integral	Floating	Male/Female	Tongue/Groove	Flat Face	Raised Face
642 A 			•	•	•	•
642 AR 	•					•
642 AR2 		•				•

- » Parallel root core is standard design
- » Integral centering ring ensures optimum gasket positioning
- » Floating centering ring allows for expansion and contraction during thermal cycling

WARNING:

Properties/applications shown throughout this brochure are typical. Your specific application should not be undertaken without independent study and evaluation for suitability. For specific application recommendations consult Garlock. Failure to select the proper sealing products could result in property damage and/or serious personal injury. Performance data published in this brochure has been developed from field testing, customer field reports and/or in-house testing.

While the utmost care has been used in compiling this brochure, we assume no responsibility for errors. Specifications subject to change without notice. This edition cancels all previous issues. Subject to change without notice.

Factors Affecting Gasket Performance

A gasket is any deformable material which, when clamped between essentially stationary faces, prevents the passage of media across the gasketed connection.

Compressing the gasket material causes the material to flow into the imperfections of the sealing areas and effect a seal. This seal prevents the escape of the contained media. In order to maintain this condition, sufficient load must be applied to the connection to oppose the hydrostatic end force created by the internal pressure of the system.

Gasket performance depends on a number of factors, including:

1. **Gasket Metal and Filler Material:** The materials must withstand the effects of:
 - a. **Temperature:** Temperature can adversely affect mechanical and chemical properties of the gasket, as well as physical characteristics such as oxidation and resilience.
 - b. **Pressure:** The media or internal piping pressure can blow out the gasket across the flange face.
 - c. **Media:** The gasket materials must be resistant to corrosive attack from the media.
2. **Joint Design:** The force holding the two flanges together must be sufficient to prevent flange separation caused by hydrostatic end force, resulting from the pressure acting on the internal area.
3. **Proper Bolt Load:** If the bolt load is insufficient to deform the gasket, or is so excessive that it crushes the gasket, a leak will occur.
4. **Surface Finish:** If the surface finish is not suitable for the gasket, a seal will not be effected.

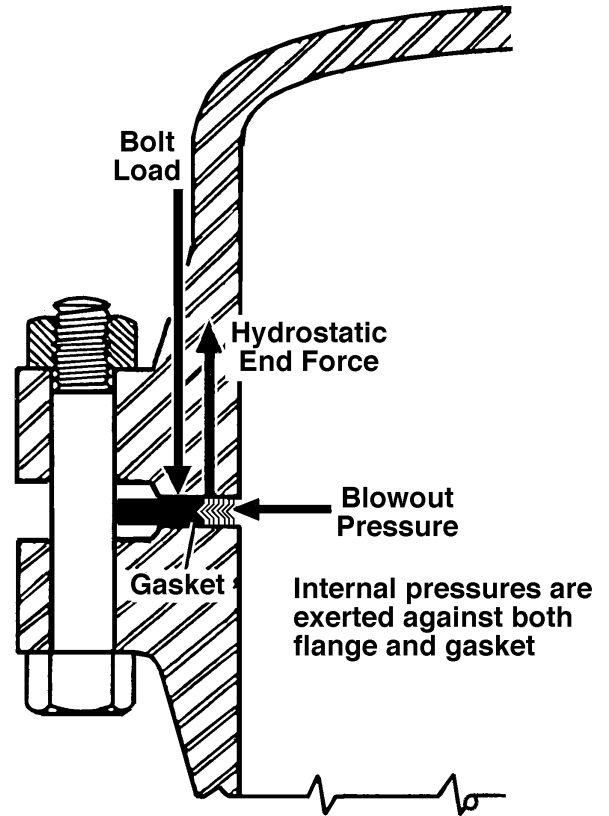

Forces Acting on a Gasket

WARNING:

Properties/applications shown throughout this brochure are typical. Your specific application should not be undertaken without independent study and evaluation for suitability. For specific application recommendations consult Garlock. Failure to select the proper sealing products could result in property damage and/or serious personal injury.

Performance data published in this brochure has been developed from field testing, customer field reports and/or in-house testing.

While the utmost care has been used in compiling this brochure, we assume no responsibility for errors. Specifications subject to change without notice. This edition cancels all previous issues. Subject to change without notice.

Spiral Wound Specifications

TEMPERATURE LIMITS FOR COMMON METALS (ASME B16.20)

Material	Minimum		Maximum		Abbreviation	Guide Ring Edge Color Code
	°F	°C	°F	°C		
304 Stainless Steel	-320	-195	1,400	760	304	Yellow
316L Stainless Steel	-150	-100	1,400	760	316L	Green
317L Stainless Steel	-150	-100	1,400	760	317L	Maroon
321 Stainless Steel	-320	-195	1,400	760	321	Turquoise
347 Stainless Steel	-320	-195	1,700	925	347	Blue
Carbon Steel	-40	-40	1,000	540	CRS	Silver
20Cb-3 (Alloy 20)	-300	-185	1,400	760	A-20	Black
HASTELLOY® B 2	-300	-185	2,000	1,090	HAST B	Brown
HASTELLOY® C 276	-300	-185	2,000	1,090	HAST C	Beige
INCOLOY® 800	-150	-100	1,600	870	IN 800	White
INCOLOY® 825	-150	-100	1,600	870	IN 825	White
INCONEL® 600	-150	-100	2,000	1,090	INC 600	Gold
INCONEL® 625	-150	-100	2,000	1,090	INC 625	Gold
INCONEL® X750	-150	-100	2,000	1,090	INX	No Color
MONEL® 400	-200	-130	1,500	820	MON	Orange
Nickel 200	-320	-195	1,400	760	NI	Red
Titanium	-320	-195	2,000	1,090	TI	Purple

STANDARD THICKNESSES

Winding	Ring(s) Inner & Outer
0.125"	3/32"
0.175"	1/8"
0.250"	3/16"
0.285"	3/16"

TEMPERATURE LIMITS FOR FILLER MATERIAL (ASME B16.20)

Material	Minimum		Maximum COT		Abbreviation	Guide Ring Edge Stripe Color Code
	°F	°C	°F	°C		
Ceramic	-350	-212	2,000	1,090	CER	Light Green
Flexible Graphite	-350	-212	850	454	F.G.	Gray
PTFE	-400	-240	500	260	PTFE	White
4122 THERMa-PUR®	-	-	1,832	1,000	4122	Light Blue

STANDARD TOLERANCES***

For non-ASME windings

Gasket Diameter	I.D.	O.D.
Up to 1"	+1/64" -0	+0 -1/32"
1" to 24"	+1/32" -0	+0 -1/32"
24" to 36"	+3/64" -0	+0 -1/16"
36" to 60"	+1/16" -0	+0 -1/16"
60" and above	+3/32" -0	+0 -3/32"

For spiral wound gaskets not otherwise specified.

Gasket		Width Limits		Compressed Thickness
Thickness	Tolerance	Minimum	Maximum	
0.125"	±0.005"	3/16"	1"††	0.090 - 0.100"
0.175"	±0.005"	1/4"	1-1/2"††	0.125 - 0.135"
0.250"	±0.005"	5/16"	1-1/2"††	0.180 - 0.200"
0.285"	±0.005"	5/16"	1-1/2"††	0.200 - 0.220"

NOTE:

Thickness tolerance is ±0.005" on spiral wound gaskets, except +0.010" -0.005" on gaskets with:

- Less than 1" ID and greater than 26" ID
- PTFE filler
- Flange widths of 1" or greater

†† Spiral wound gaskets can be made to large maximum widths if required. Call Garlock for details.

HASTELLOY® is a registered trademark of Haynes International.

INCOLOY® and INCONEL® are registered trademarks of Inco Alloys International, Inc.

MONEL® is a registered trademark of International Nickel.

** Measured across the metallic portion of the gasket not including the filler, which may protrude slightly.

*** Tolerances for standard ASME gaskets are found under NOTES in the tables of dimensions.

Flange Types

FLAT FACE

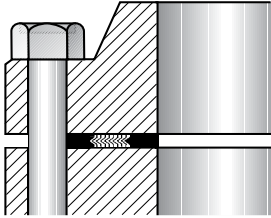

Unconfined Gasket

- » Mating faces of both flanges are flat
- » Gasket may be ring type, or full face, which covers the entire face both inside and outside the bolts (ring gaskets are not acceptable in many flat face flanges) due to flange materials of construction

MALE-FEMALE

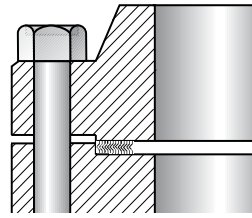

Semi-Confined Gasket

- » Depth of female (recessed) face normally equal to or less than height of male (raised) face, to prevent metal-to-metal contact during gasket compression
- » Recessed O.D. normally is not more than 1/16" larger than the O.D. of the male face
- » Joint must be pried apart for disassembly

RAISED FACE

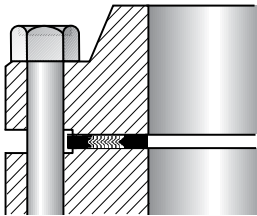

Unconfined Gasket

- » Flange sealing surface is reduced to achieve higher seating stress
- » Gasket is usually ring type, contained entirely within bolt circle

TONGUE AND GROOVE

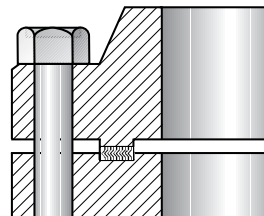

Fully Confined Gasket

- » Groove depth is equal to or less than tongue height
- » Groove usually not over 1/16" wider than tongue
- » Gasket dimensions will match tongue dimensions
- » Joint must be pried apart for disassembly

RING JOINT

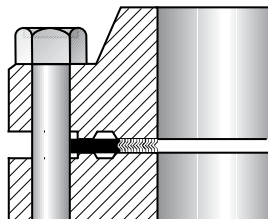

Also Called "API Joint" or "RTJ"

- » Both flange faces have matching flat-bottomed grooves with sides tapered from the vertical at 23°
- » Gasket seats on flat section of flange between bore and ring joint groove
- » Garlock spiral wound gaskets can replace solid metal ring joint gaskets (RW-RJ or RWI-RJ)
- » Special Kammprofile gaskets are also available

GROOVE TO FLAT

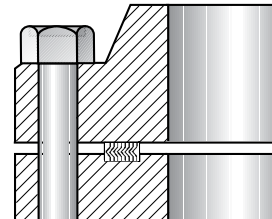

Fully Confined Gasket

- » One flange face is flat, the other is recessed
- » For applications requiring accurate control of gasket compression
- » Only resilient gaskets are recommended—spiral wound, hollow metal O-ring, pressure-actuated, and metal-jacketed gaskets

Gasket Selection by Flange Type

	RW	RWI	EDGE®	TANDEM SEAL	SW	RW-RJ	RWI-RJ	LMF	LTG	STG	HEAT SHIELD™
Raised Face	•	•	•	•							•
Ring Joint						•	•				
Male-Female					•			•	•	•	
Tongue & Groove					•				•	•	
Groove to Flat					•						

FLANGE SURFACE FINISH

The surface finish of a flange is described as follows:

Roughness

- » Average of peaks and valleys measured from midline of flange surface (in micro-inch or micro-meter)

Preferred finish per ASME B16.5 or B16.47;

- » Serrated finish cut with a 1/16" radius (1.5mm) round tool.
- » 45-55 grooves per inch (1.8 to 2.2 grooves per mm)

RECOMMENDED VALUES

Spiral Wound Gaskets	125-250 micro-inch (3.2-6.3 micro-meter)
Corrugated Metal Gaskets (CMG)	125-250 micro-inch (3.2-6.3 micro-meter)
Kammprofile Gaskets	125-250 micro-inch (3.2-6.3 micro-meter)
Jacketed or Metal Clad Gaskets	63-80 micro-inch (1.6-2.0 micro-meter)
Solid Metal Gaskets	63-80 micro-inch (1.6-2.0 micro-meter)

NOTE:

These values are suggested only and not mandatory; however they are based upon the best cross-section of successful design experience currently available.

WARNING:

Properties/applications shown throughout this brochure are typical. Your specific application should not be undertaken without independent study and evaluation for suitability. For specific application recommendations consult Garlock. Failure to select the proper sealing products could result in property damage and/or serious personal injury.

Performance data published in this brochure has been developed from field testing, customer field reports and/or in-house testing.

While the utmost care has been used in compiling this brochure, we assume no responsibility for errors. Specifications subject to change without notice. This edition cancels all previous issues. Subject to change without notice.

Maximum Flange Bore for FLEXSEAL® RW/RWI

Flange Size (NPS)	Pressure Class											
	75#	150#	300#	400#	600#	900#	1500#	2500#				
1/2"	No Recommendation in 75 lb. flanges	Weld-neck only ²	No flanges, use class 600	Weld-neck only ²	No flanges, use class 1500	Weld-neck only ²	Weld-neck with standard wall bore (includes nozzle ⁴ but excludes slip-on)	Weld-neck only ²				
3/4"												
1"												
1 1/4"		Slip-on ³ Weld-neck ²		Slip-on ³ Weld-neck ²								
1 1/2"												
2"		Slip-on ³ Weld-neck, any bore		Slip-on ³ Weld-neck, any bore								
2 1/2"												
3"		Slip-on, Weld-neck, any bore		Weld-neck with schedule 10S bore described in ASME B36.19M (includes nozzle ⁴ but excludes slip-on)		Slip-on, Weld-neck any bore			Weld-neck with standard wall bore (includes nozzle ⁴ but excludes slip-on)	Weld-neck w/ schedule 60 bore		
4"												
6"						Weld-neck w/ schedule 80 bore						
8"												
10"						Weld-neck with schedule 10 bore described in ASME B36.10M (excludes nozzle ⁴ and slip-on ⁵)					Weld-neck w/ standard wall bore (excludes nozzle and slip-on)	No flanges
12"												
14"												
16"												
18"												
20"												
24"	Weld-neck w/ sched. 40 bore											

NOTES:

1. Inner rings are recommended for all graphite filled gaskets, required for all PTFE filled gaskets, and for NPS 24 and larger in Class 900#, NPS 12 and larger in Class 1500#, and NPS 4 and larger in Class 2500#. (See page 5 for full description) These inner rings may extend into the pipe bore a maximum of 0.06" (1.5 mm) under the worst combination or maximum bore, eccentric installation, and additive tolerances. Purchaser should specify inner ring material.
2. In these sizes the gasket is suitable for a weld-neck flange with a standard wall bore, if the gasket and the flange are assembled concentrically. This also applies to a nozzle. It is the user's responsibility to determine if the gasket is satisfactory for the flange of any larger bore.
3. Gaskets in these sizes are suitable for slip-on flanges only if the gaskets and flanges are assembled concentrically.
4. A nozzle is a long welded neck; the bore equals the flange NPS.
5. An NPS 24 gasket is suitable for nozzles.

WARNING:

Properties/applications shown throughout this brochure are typical. Your specific application should not be undertaken without independent study and evaluation for suitability. For specific application recommendations consult Garlock. Failure to select the proper sealing products could result in property damage and/or serious personal injury.

Performance data published in this brochure has been developed from field testing, customer field reports and/or in-house testing.

While the utmost care has been used in compiling this brochure, we assume no responsibility for errors. Specifications subject to change without notice. This edition cancels all previous issues. Subject to change without notice.

Styles RW, RWI Dimensions 1/4" to 24" Flanges

ASME B16.20 GASKETS FOR ASME B16.5 FLANGES

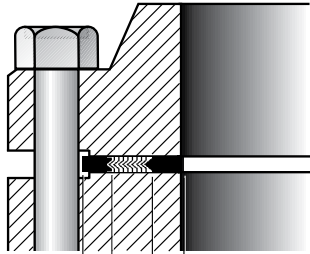

- ← **A** Inner Ring I.D.
- ← **B** Sealing Element I.D.
- ← **C** Sealing Element O.D.
- ← **D** Centering (Outer) Ring O.D.

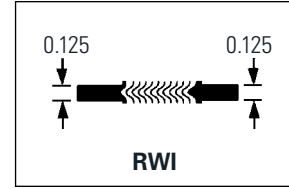
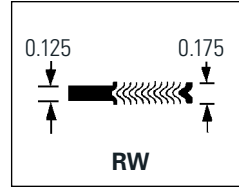

150#

Size NPS	Inner Ring ¹		Sealing Element		Outer Ring	
	Inside (A) Diameter	Inside (B) Diameter	Outside (C) Diameter	Outside (D) Diameter	Outside (D) Diameter	Outside (D) Diameter
1/4*	—	0.50	0.88	1.75		
1/2	0.56	0.75	1.25	1.88		
3/4	0.81	1.00	1.56	2.25		
1	1.06	1.25	1.88	2.63		
1-1/4	1.50	1.88	2.38	3.00		
1-1/2	1.75	2.13	2.75	3.38		
2	2.19	2.75	3.38	4.13		
2-1/2	2.62	3.25	3.88	4.88		
3	3.19	4.00	4.75	5.38		
3-1/2*	—	4.50	5.25	6.38		
4	4.19	5.00	5.88	6.88		
4-1/2*	—	5.50	6.50	7.00		
5	5.19	6.13	7.00	7.75		
6	6.19	7.19	8.25	8.75		
8	8.50	9.19	10.38	11.00		
10	10.56	11.31	12.50	13.38		
12	12.50	13.38	14.75	16.13		
14	13.75	14.63	16.00	17.75		
16	15.75	16.63	18.25	20.25		
18	17.69	18.69	20.75	21.63		
20	19.69	20.69	22.75	23.88		
24	23.75	24.75	27.00	28.25		

* ASME B16.20 does not include dimensions for NPS 1/4, 3-1/2 or 4-1/2, or Class 400 flanges up to NPS 3 and Class 900 flanges up to NPS 2-1/2. Dimensions in inches.

300#

Size NPS	Inner Ring ¹		Sealing Element		Outer Ring	
	Inside (A) Diameter	Inside (B) Diameter	Outside (C) Diameter	Outside (D) Diameter	Outside (D) Diameter	Outside (D) Diameter
1/4*	—	0.50	0.88	1.75		
1/2	0.56	0.75	1.25	2.13		
3/4	0.81	1.00	1.56	2.63		
1	1.06	1.25	1.88	2.88		
1-1/4	1.50	1.88	2.38	3.25		
1-1/2	1.75	2.13	2.75	3.75		
2	2.19	2.75	3.38	4.38		
2-1/2	2.62	3.25	3.88	5.13		
3	3.19	4.00	4.75	5.88		
3-1/2*	—	4.50	5.25	6.50		
4	4.19	5.00	5.88	7.13		
4-1/2*	—	5.50	6.50	7.75		
5	5.19	6.13	7.00	8.50		
6	6.19	7.19	8.25	9.88		
8	8.50	9.19	10.38	12.13		
10	10.56	11.31	12.50	14.25		
12	12.50	13.38	14.75	16.63		
14	13.75	14.63	16.00	19.13		
16	15.75	16.63	18.25	21.25		
18	17.69	18.69	20.75	23.50		
20	19.69	20.69	22.75	25.75		
24	23.75	24.75	27.00	30.50		

NOTES:

1. Inner rings are recommended for all graphite filled gaskets, required for all PTFE filled gaskets, and for NPS 24 and larger in Class 900#, NPS 12 and larger in Class 1500#, and NPS 4 and larger in Class 2500#.
2. The gasket outside Diameter tolerance for NPS 1/2 through NPS 8 is ± 0.03 "; for NPS 10 through NPS 24, $+0.06$ ", -0.03 ".
3. The gasket inside Diameter tolerance for NPS 1/2 through NPS 8 is ± 0.016 "; for NPS 10 through NPS 24, ± 0.03 ".

Styles RW, RWI Dimensions 1/4" to 24" Flanges

400#

Size NPS	Inner Ring ¹		Sealing Element		Outer Ring
	Inside (A) Diameter	Inside (B) Diameter	Outside (C) Diameter	Outside (D) Diameter	Outside (D) Diameter
1/4*	—	0.50	0.88	1.75	1.75
1/2	—	0.75	1.25	2.13	2.13
3/4	—	1.00	1.56	2.63	2.63
1	—	1.25	1.88	2.88	2.88
1-1/4	—	1.88	2.38	3.25	3.25
1-1/2	—	2.13	2.75	3.75	3.75
2	—	2.75	3.38	4.38	4.38
2-1/2	—	3.25	3.88	5.13	5.13
3	—	4.00	4.75	5.88	5.88
3-1/2*	—	4.13	5.25	6.38	6.38
4	4.04	4.75	5.88	7.00	7.00
4-1/2*	—	5.31	6.50	7.63	7.63
5	5.05	5.81	7.00	8.38	8.38
6	6.10	6.88	8.25	9.75	9.75
8	8.10	8.88	10.38	12.13	12.13
10	10.05	10.81	12.50	14.13	14.13
12	12.10	12.88	14.75	16.50	16.50
14	13.50	14.25	16.00	19.00	19.00
16	15.35	16.25	18.25	21.13	21.13
18	17.25	18.50	20.75	23.38	23.38
20	19.25	20.50	22.75	25.50	25.50
24	23.25	24.75	27.00	30.25	30.25

600#

Size NPS	Inner Ring ¹		Sealing Element		Outer Ring
	Inside (A) Diameter	Inside (B) Diameter	Outside (C) Diameter	Outside (D) Diameter	Outside (D) Diameter
1/4*	—	0.50	0.88	1.75	1.75
1/2	0.56	0.75	1.25	2.13	2.13
3/4	0.81	1.00	1.56	2.63	2.63
1	1.06	1.25	1.88	2.88	2.88
1-1/4	1.50	1.88	2.38	3.25	3.25
1-1/2	1.75	2.13	2.75	3.75	3.75
2	2.19	2.75	3.38	4.38	4.38
2-1/2	2.62	3.25	3.88	5.13	5.13
3	3.19	4.00	4.75	5.88	5.88
3-1/2*	—	4.13	5.25	6.38	6.38
4	4.04	4.75	5.88	7.63	7.63
4-1/2*	—	5.31	6.50	8.25	8.25
5	5.05	5.81	7.00	9.50	9.50
6	6.10	6.88	8.25	10.50	10.50
8	8.10	8.88	10.38	12.63	12.63
10	10.05	10.81	12.50	15.75	15.75
12	12.10	12.88	14.75	18.00	18.00
14	13.50	14.25	16.00	19.38	19.38
16	15.35	16.25	18.25	22.25	22.25
18	17.25	18.50	20.75	24.13	24.13
20	19.25	20.50	22.75	26.88	26.88
24	23.25	24.75	27.00	31.13	31.13

* ASME B16.20 does not include dimensions for NPS 1/4, 3-1/2 or 4-1/2, or Class 400# flanges up to NPS 3 and Class 900# flanges up to NPS 2-1/2.
Dimensions in inches.

NOTES:

1. Inner rings are recommended for all graphite filled gaskets, required for all PTFE filled gaskets, and for NPS 24 and larger in Class 900#, NPS 12 and larger in Class 1500#, and NPS 4 and larger in Class 2500#.
2. The gasket outside Diameter tolerance for NPS 1/2 through NPS 8 is ± 0.03 "; for NPS 10 through NPS 24, $+0.06$ ", -0.03 ".
3. The gasket inside Diameter tolerance for NPS 1/2 through NPS 8 is ± 0.016 "; for NPS 10 through NPS 24, ± 0.03 ".
4. The Inner Ring inside diameter shown for NPS 1-1/4" through 2-1/2" in 1500# & 2500# class flanges will produce an inner ring width of 0.12", a practical minimum for production purposes.
5. There are no Class 400# flanges in NPS 1/2 through NPS 3 (use Class 600), Class 900# flanges in NPS 1/2 through NPS 2-1/2 (use Class 1500#), or Class 2500# flanges NPS 14 and larger.

Styles RW, RWI Dimensions 1/4" to 24" Flanges

900#

Size NPS	Inner Ring ¹		Sealing Element		Outer Ring	
	Inside (A) Diameter	Inside (B) Diameter	Outside (C) Diameter	Outside (D) Diameter	Outside (D) Diameter	Outside (D) Diameter
1/2*	—	0.75	1.25	2.50		
3/4*	—	1.00	1.56	2.75		
1*	—	1.25	1.88	3.13		
1-1/4*	—	1.56	2.38	3.50		
1-1/2*	—	1.88	2.75	3.88		
2*	—	2.31	3.38	5.63		
2-1/2*	—	2.75	3.88	6.50		
3	3.10	3.75	4.75	6.63		
3-1/2*	—	4.13	5.25	7.50		
4	4.04	4.75	5.88	8.13		
4-1/2*	—	5.31	6.50	9.38		
5	5.05	5.81	7.00	9.75		
6	6.10	6.88	8.25	11.38		
8	7.75	8.75	10.13	14.13		
10	9.69	10.88	12.25	17.13		
12	11.50	12.75	14.50	19.63		
14	12.63	14.00	15.75	20.50		
16	14.75	16.25	18.00	22.63		
18	16.75	18.25	20.50	25.13		
20	19.00	20.50	22.50	27.50		
24	23.25	24.75	26.75	33.00		

1500#

Size NPS	Inner Ring ¹		Sealing Element		Outer Ring	
	Inside (A) Diameter	Inside (B) Diameter	Outside (C) Diameter	Outside (D) Diameter	Outside (D) Diameter	Outside (D) Diameter
1/2	0.56	0.75	1.25	2.50		
3/4	0.81	1.00	1.56	2.75		
1	1.06	1.25	1.88	3.13		
1-1/4	1.31	1.56	2.38	3.50		
1-1/2	1.63	1.88	2.75	3.88		
2	2.06	2.31	3.38	5.63		
2-1/2	2.50	2.75	3.88	6.50		
3	3.10	3.63	4.75	6.88		
3-1/2*	—	4.13	5.25	7.38		
4	3.85	4.63	5.88	8.25		
4-1/2*	—	5.31	6.50	9.13		
5	4.90	5.63	7.00	10.00		
6	5.80	6.75	8.25	11.13		
8	7.75	8.50	10.13	13.88		
10	9.69	10.50	12.25	17.13		
12	11.50	12.75	14.50	20.50		
14	12.63	14.25	15.75	22.75		
16	14.50	16.00	18.00	25.25		
18	16.75	18.25	20.50	27.75		
20	18.75	20.50	22.50	29.75		
24	22.75	24.25	26.75	35.50		

2500#

Size NPS	Inner Ring ¹		Sealing Element		Outer Ring	
	Inside (A) Diameter	Inside (B) Diameter	Outside (C) Diameter	Outside (D) Diameter	Outside (D) Diameter	Outside (D) Diameter
1/2	0.56	0.75	1.25	2.75		
3/4	0.81	1.00	1.56	3.00		
1	1.06	1.25	1.88	3.38		
1-1/4	1.31	1.56	2.38	4.13		
1-1/2	1.63	1.88	2.75	4.63		
2	2.06	2.31	3.38	5.75		
2-1/2	2.50	2.75	3.88	6.63		
3	3.10	3.63	4.75	7.75		
4	3.85	4.63	5.88	9.25		
5	4.90	5.63	7.00	11.00		
6	5.80	6.75	8.25	12.50		
8	7.75	8.50	10.13	15.25		
10	9.69	10.63	12.25	18.75		
12	11.50	12.50	14.50	21.63		

* ASME B16.20 does not include dimensions for NPS 1/4, 3-1/2 or 4-1/2, or Class 400# flanges up to NPS 3 and Class 900# flanges up to NPS 2-1/2. Dimensions in inches.

WARNING:

Properties/applications shown throughout this brochure are typical. Your specific application should not be undertaken without independent study and evaluation for suitability. For specific application recommendations consult Garlock. Failure to select the proper sealing products could result in property damage and/or serious personal injury.

Performance data published in this brochure has been developed from field testing, customer field reports and/or in-house testing.

While the utmost care has been used in compiling this brochure, we assume no responsibility for errors. Specifications subject to change without notice. This edition cancels all previous issues. Subject to change without notice.

Styles RW, RWI Dimensions 22" to 60" Series A Flanges

ASME B16.20 GASKETS FOR ASME B16.47
SERIES A FLANGES (MSS SP-44)

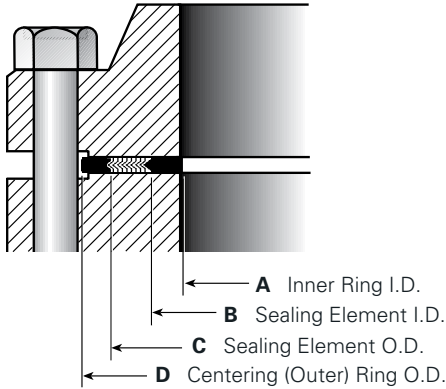

300#

Size NPS	Inner Ring ¹		Sealing Element		Outer Ring
	Inside (A) Diameter	Inside (B) Diameter	Outside (C) Diameter	Outside (D) Diameter	Outside (D) Diameter
22*	—	22.75	24.75	27.75	
26	25.75	27.00	29.00	32.88	
28	27.75	29.00	31.00	35.38	
30	29.75	31.25	33.25	37.50	
32	31.75	33.50	35.50	39.63	
34	33.75	35.50	37.50	41.63	
36	35.75	37.63	39.63	44.00	
38	37.50	38.50	40.00	41.50	
40	39.50	40.25	42.13	43.88	
42	41.50	42.25	44.13	45.88	
44	43.50	44.50	46.50	48.00	
46	45.38	46.38	48.38	50.13	
48	47.63	48.63	50.63	52.13	
50	49.00	51.00	53.00	54.25	
52	52.00	53.00	55.00	56.25	
54	53.25	55.25	57.25	58.75	
56	55.25	57.25	59.25	60.75	
58	57.00	59.50	61.50	62.75	
60	60.00	61.50	63.50	64.75	

150#

Size NPS	Inner Ring ¹		Sealing Element		Outer Ring
	Inside (A) Diameter	Inside (B) Diameter	Outside (C) Diameter	Outside (D) Diameter	Outside (D) Diameter
22*	—	22.75	24.00	26.00	
26	25.75	26.50	27.75	30.50	
28	27.75	28.50	29.75	32.75	
30	29.75	30.50	31.75	34.75	
32	31.75	32.50	33.88	37.00	
34	33.75	34.50	35.88	39.00	
36	35.75	36.50	38.13	41.26	
38	37.75	38.50	40.13	43.75	
40	39.75	40.50	42.13	45.75	
42	41.75	42.50	44.25	48.00	
44	43.75	44.50	46.38	50.25	
46	45.75	46.50	48.38	52.25	
48	47.75	48.50	50.38	54.50	
50	49.75	50.50	52.50	56.50	
52	51.75	52.50	54.50	58.75	
54	53.50	54.50	56.50	61.00	
56	55.50	56.50	58.50	63.25	
58	57.50	58.50	60.50	65.50	
60	59.50	60.50	62.50	67.50	

400#

Size NPS	Inner Ring ¹		Sealing Element		Outer Ring
	Inside (A) Diameter	Inside (B) Diameter	Outside (C) Diameter	Outside (D) Diameter	Outside (D) Diameter
22*	—	22.75	24.75	27.63	
26	26.00	27.00	29.00	32.75	
28	28.00	29.00	31.00	35.13	
30	29.75	31.25	33.25	37.25	
32	32.00	33.50	35.50	39.50	
34	34.00	35.50	37.50	41.50	
36	36.13	37.63	39.63	44.00	
38	37.50	38.25	40.25	42.25	
40	39.38	40.38	42.38	43.38	
42	41.38	42.38	44.38	46.38	
44	43.50	44.50	46.50	48.50	
46	46.00	47.00	49.00	50.75	
48	47.50	49.00	51.00	53.00	
50	49.50	51.00	53.00	55.25	
52	51.50	53.00	55.00	57.25	
54	53.25	55.25	57.25	59.75	
56	55.25	57.25	59.25	61.75	
58	57.25	59.25	61.25	63.75	
60	59.75	61.75	63.75	66.25	

* Dimensions for 22" from MSS SP-44; this size is not listed in ASME B 16.47

Styles RW, RWI Dimensions 22" to 60" Series A Flanges

ASME B16.20 GASKETS FOR ASME B16.47 SERIES A FLANGES (MSS SP-44)

600#

Size NPS	Inner Ring ¹		Sealing Element		Outer Ring	
	Inside (A) Diameter	Inside (B) Diameter	Outside (C) Diameter	Outside (D) Diameter	Outside (D) Diameter	Outside (D) Diameter
22*	—	22.75	24.75	28.88		
26	25.50	27.00	29.00	34.13		
28	27.50	29.00	31.00	36.00		
30	29.75	31.25	33.25	38.25		
32	32.00	33.50	35.50	40.25		
34	34.00	35.50	37.50	42.25		
36	36.13	37.63	39.63	44.50		
38	37.50	39.00	41.00	43.50		
40	39.75	41.25	43.25	45.50		
42	42.00	43.50	45.50	48.00		
44	43.75	45.75	47.75	50.00		
46	45.75	47.75	49.75	52.25		
48	48.00	50.00	52.00	54.75		
50	50.00	52.00	54.00	57.00		
52	52.00	54.00	56.00	59.00		
54	54.25	56.25	58.25	61.25		
56	56.25	58.25	60.25	63.50		
58	58.00	60.50	62.50	65.50		
60	60.25	62.75	64.75	68.25		

900#

Size NPS	Inner Ring ¹		Sealing Element		Outer Ring	
	Inside (A) Diameter	Inside (B) Diameter	Outside (C) Diameter	Outside (D) Diameter	Outside (D) Diameter	Outside (D) Diameter
22*	—	24.25	27.00	33.00		
26	26.00	27.00	29.00	34.75		
28	28.00	29.00	31.00	37.25		
30	30.25	31.25	33.25	39.75		
32	32.00	33.50	35.50	42.25		
34	34.00	35.50	37.50	44.75		
36	36.25	37.75	39.75	47.25		
38	39.75	40.75	42.75	47.25		
40	41.75	43.25	45.25	49.25		
42	43.75	45.25	47.25	51.25		
44	45.50	47.50	49.50	53.88		
46	48.00	50.00	52.00	56.50		
48	50.00	52.00	54.00	58.50		

* Dimensions for 22" from MSS SP-44; this size is not listed in ASME B 16.47

NOTES:

1. Inner rings are recommended for all graphite filled gaskets, required for all PTFE filled gaskets, and for NPS 24 and larger in Class 900#, NPS 12 and larger in Class 1500#, and NPS 4 and larger in Class 2500#.
2. The gasket inside Diameter tolerance for NPS 26 through NPS 34 is $\pm 0.03"$; for NPS 36 through NPS 60 is $\pm 0.05"$.
3. The gasket outside Diameter tolerance for NPS 26 through NPS 60 is $\pm 0.06"$.
4. There are no Class 900# flanges in NPS 50 and larger.

WARNING:

Properties/applications shown throughout this brochure are typical. Your specific application should not be undertaken without independent study and evaluation for suitability. For specific application recommendations consult Garlock. Failure to select the proper sealing products could result in property damage and/or serious personal injury.

Performance data published in this brochure has been developed from field testing, customer field reports and/or in-house testing.

While the utmost care has been used in compiling this brochure, we assume no responsibility for errors. Specifications subject to change without notice. This edition cancels all previous issues. Subject to change without notice.

Styles RW, RWI Dimensions 26" to 60" Series B Flanges

ASME B16.20 GASKETS FOR ASME B16.47
SERIES B FLANGES (API-605)

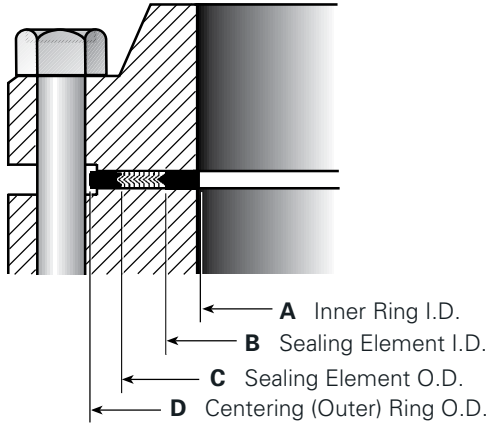

150#

Size NPS	Inner Ring ¹		Sealing Element		Outer Ring
	Inside (A) Diameter	Inside (B) Diameter	Outside (C) Diameter	Outside (D) Diameter	
26	25.75	26.50	27.50	28.56	
28	27.75	28.50	29.50	30.56	
30	29.75	30.50	31.50	32.56	
32	31.75	32.50	33.50	34.69	
34	33.75	34.50	35.75	36.81	
36	35.75	36.50	37.75	38.88	
38	37.75	38.37	39.75	41.13	
40	39.75	40.25	41.88	43.13	
42	41.75	42.50	43.88	45.13	
44	43.75	44.25	45.88	47.13	
46	45.75	46.50	48.19	49.44	
48	47.75	48.50	50.00	51.44	
50	49.75	50.50	52.19	53.44	
52	51.75	52.50	54.19	55.44	
54	53.75	54.50	56.00	57.63	
56	56.00	56.88	58.18	59.63	
58	58.19	59.07	60.19	62.19	
60	60.44	61.31	62.44	64.19	

75# | LARGE DIAMETER WELD NECK FLANGES

Size NPS	Sealing Element		Outer Ring
	Inside (B) Diameter	Outside (C) Diameter	Outside (D) Diameter
26	26.25	27.00	27.88
28	28.25	29.13	29.88
30	30.25	31.13	31.88
32	32.25	33.13	33.88
34	34.25	35.13	35.88
36	36.25	37.25	38.31
38	38.25	39.31	40.31
40	40.25	41.31	42.31
42	42.25	43.25	44.31
44	44.25	45.50	46.50
46	46.25	47.50	48.50
48	48.38	49.50	50.50
50	50.25	51.50	52.50
52	52.38	53.63	54.63
54	54.38	55.63	56.63
56	56.50	57.88	58.88
58	58.50	59.88	60.88
60	60.50	61.75	62.88

300#

Size NPS	Inner Ring ¹		Sealing Element		Outer Ring
	Inside (A) Diameter	Inside (B) Diameter	Outside (C) Diameter	Outside (D) Diameter	
26	25.75	26.50	28.00	30.38	
28	27.75	28.50	30.00	32.50	
30	29.75	30.50	32.00	34.88	
32	31.75	32.50	34.00	37.00	
34	33.75	34.50	36.00	39.13	
36	35.75	36.50	38.00	41.25	
38	38.25	39.75	41.25	43.25	
40	40.25	41.75	43.25	45.25	
42	42.75	43.75	45.25	47.25	
44	44.25	45.75	47.25	49.25	
46	46.38	47.88	49.38	51.88	
48	48.50	49.75	51.63	53.88	
50	49.88	51.88	53.38	55.88	
52	51.88	53.88	55.38	57.88	
54	53.75	55.25	57.25	60.25	
56	56.25	58.25	60.00	62.75	
58	58.44	60.44	61.94	65.19	
60	61.31	62.56	64.19	67.19	

Styles RW, RWI Dimensions 26" to 60" Series B Flanges

ASME B16.20 GASKETS FOR ASME B16.47 SERIES B FLANGES (API-605)

400#

Size NPS	Inner Ring ¹	Sealing Element		Outer Ring
	Inside (A) Diameter	Inside (B) Diameter	Outside (C) Diameter	Outside (D) Diameter
26	25.75	26.25	27.50	29.38
28	27.63	28.13	29.50	31.50
30	29.63	30.13	31.75	33.75
32	31.50	32.00	33.88	35.88
34	33.50	34.13	35.88	37.88
36	35.38	36.13	38.00	40.25
38	37.50	38.25	40.25	42.25
40	39.38	40.38	42.38	44.38
42	41.38	42.38	44.38	46.38
44	43.50	44.50	46.50	48.50
46	46.00	47.00	49.00	50.75
48	47.50	49.00	51.00	53.00
50	49.50	51.00	53.00	55.25
52	51.50	53.00	55.00	57.25
54	53.25	55.25	57.25	59.75
56	55.25	57.25	59.25	61.75
58	57.25	59.25	61.25	63.75
60	59.75	61.75	63.75	66.25

600#

Size NPS	Inner Ring ¹	Sealing Element		Outer Ring
	Inside (A) Diameter	Inside (B) Diameter	Outside (C) Diameter	Outside (D) Diameter
26	25.38	26.13	28.13	30.13
28	27.25	27.75	29.75	32.25
30	29.63	30.63	32.63	34.63
32	31.25	32.75	34.75	36.75
34	33.50	35.00	37.00	39.25
36	35.50	37.00	39.00	41.25
38	37.50	39.00	41.00	43.50
40	39.75	41.25	43.25	45.50
42	42.00	43.50	45.50	48.00
44	43.75	45.75	47.75	50.00
46	45.75	47.75	49.75	52.25
48	48.00	50.00	52.00	54.75
50	50.00	52.00	54.00	57.00
52	52.00	54.00	56.00	59.00
54	54.25	56.25	58.25	61.25
56	56.25	58.25	60.25	63.50
58	58.00	60.50	62.50	65.50
60	60.25	62.75	64.75	68.25

900#

Size NPS	Inner Ring ¹	Sealing Element		Outer Ring
	Inside (A) Diameter	Inside (B) Diameter	Outside (C) Diameter	Outside (D) Diameter
26	26.25	27.25	29.50	33.00
28	28.25	29.25	31.50	35.50
30	30.75	31.75	33.75	37.75
32	33.00	34.00	36.00	40.00
34	35.25	36.25	38.25	42.25
36	36.25	37.25	39.25	44.25
38	39.75	40.75	42.75	47.25
40	41.75	43.25	45.25	49.25
42	43.75	45.25	47.25	51.25
44	45.50	47.50	49.50	53.88
46	48.00	50.00	52.00	56.50
48	50.00	52.00	54.00	58.50

NOTES:

1. Inner rings are recommended for all graphite filled gaskets, required for all PTFE filled gaskets, and for NPS 24 and larger in Class 900#, NPS 12 and larger in Class 1500#, and NPS 4 and larger in Class 2500#.
2. The gasket inside Diameter tolerance for NPS 26 through NPS 34 is $\pm 0.03"$; for NPS 36 through NPS 60 is $\pm 0.05"$.
3. The gasket outside Diameter tolerance for NPS 26 through NPS 60 is $\pm 0.06"$.
4. There are no Class 900# flanges in NPS 50 and larger.

WARNING:

Properties/applications shown throughout this brochure are typical. Your specific application should not be undertaken without independent study and evaluation for suitability. For specific application recommendations consult Garlock. Failure to select the proper sealing products could result in property damage and/or serious personal injury.

Performance data published in this brochure has been developed from field testing, customer field reports and/or in-house testing.

While the utmost care has been used in compiling this brochure, we assume no responsibility for errors. Specifications subject to change without notice. This edition cancels all previous issues. Subject to change without notice.

Styles RW Dimensions Taylor Forge Flanges, 26-96"

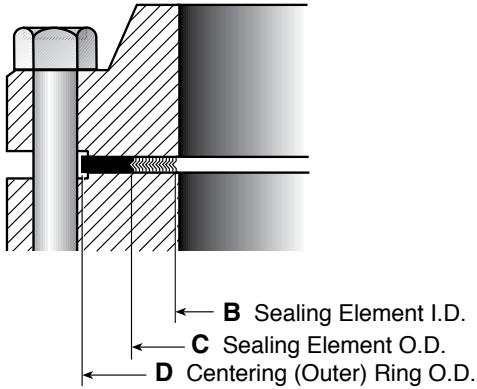

75# | SLIP-ON AND BLIND

Size NPS	Sealing Element		Outer Ring
	Inside (B) Diameter	Outside (C) Diameter	Outside (D) Diameter
26	27.00	28.25	30.13
28	29.00	30.25	32.13
30	31.00	32.25	34.13
32	33.13	34.38	36.38
34	35.13	36.50	38.38
36	37.13	38.50	40.38
42	43.25	44.75	46.63
48	49.25	50.88	52.63
54	55.38	57.75	59.13
60	61.38	63.38	65.13
66	67.50	69.50	71.75
72	73.50	75.50	77.75

75# | WELD NECK AND BLIND

Size NPS	Sealing Element		Outer Ring
	Inside (B) Diameter	Outside (C) Diameter	Outside (D) Diameter
26	26.50	27.75	28.75
28	28.50	29.75	30.75
30	30.50	31.75	32.75
32	32.50	33.75	35.13
34	34.50	35.88	37.13
36	36.50	37.88	39.13
42	42.50	44.00	45.63
48	48.50	50.13	51.63
54	54.50	56.38	57.88
60	60.50	62.50	63.88
66	66.50	68.50	70.25
72	72.50	74.50	76.25

125#

Size NPS	Sealing Element		Outer Ring
	Inside (B) Diameter	Outside (C) Diameter	Outside (D) Diameter
22	22.75	24.00	26.00
26	26.50	27.75	30.50
28	28.50	29.75	32.75
30	30.50	31.75	34.75
32	32.50	33.88	37.00
34	34.50	35.88	39.00
36	36.50	38.13	41.25
38	38.50	40.13	43.75
40	40.50	42.13	45.75
42	42.50	44.25	48.00
44	44.50	46.38	50.25
46	46.50	48.38	52.25
48	48.50	50.38	54.50
50	50.50	52.50	56.50
52	52.50	54.50	58.75
54	54.50	56.50	61.00
60	60.50	62.50	67.50
66	71.00	72.75	74.25
72	77.50	79.25	80.75
84	90.25	92.00	93.50
96	103.00	104.75	106.25

Styles RW Dimensions Taylor Forge Flanges, 26-96"

175#

Size NPS	Sealing Element		Outer Ring
	Inside (B) Diameter	Outside (C) Diameter	Outside (D) Diameter
26	26.50	27.75	29.13
28	28.50	29.75	31.13
30	30.50	31.75	33.38
32	32.50	33.75	35.38
34	34.50	35.88	37.50
36	36.50	37.88	39.50
38	38.50	39.88	41.50
40	40.50	42.00	43.50
42	42.50	44.00	45.88
44	44.50	46.00	47.88
46	46.50	48.00	49.88
48	48.50	50.13	51.88
50	50.50	52.25	53.88
52	52.50	54.38	56.13
54	54.50	56.75	58.13
60	60.50	62.50	64.13
66	67.88	68.88	70.13
72	73.38	75.13	76.63
84	87.00	88.75	90.25
96	99.00	100.75	102.25

350#

Size NPS	Sealing Element		Outer Ring
	Inside (B) Diameter	Outside (C) Diameter	Outside (D) Diameter
26	26.50	27.75	29.63
28	28.50	29.75	31.63
30	30.50	31.75	33.88
32	32.50	33.88	35.88
34	34.50	35.88	37.88
36	36.50	38.13	40.38
38	38.50	40.13	42.38
40	40.50	42.13	44.38
42	42.50	44.25	46.63
44	44.50	46.38	49.00
46	46.50	48.38	51.00
48	48.50	50.38	53.00
52	52.50	54.50	57.38
54	54.50	56.50	59.38
60	60.50	62.50	65.38
66	66.50	68.50	72.50
72	72.25	77.00	78.50
84	88.38	90.13	91.63
96	100.75	102.50	104.00

250#

Size NPS	Sealing Element		Outer Ring
	Inside (B) Diameter	Outside (C) Diameter	Outside (D) Diameter
26	26.50	27.75	32.75
28	28.50	29.75	35.25
30	30.50	31.75	37.50
32	32.50	33.88	39.75
34	34.50	35.88	41.75
36	36.50	38.13	44.00
38	38.50	40.13	46.00
40	40.50	42.13	48.25
42	42.50	44.25	50.75
44	44.50	46.38	53.00
46	46.50	48.38	55.25
48	48.50	50.38	58.75

WARNING:

Properties/applications shown throughout this brochure are typical. Your specific application should not be undertaken without independent study and evaluation for suitability. For specific application recommendations consult Garlock. Failure to select the proper sealing products could result in property damage and/or serious personal injury.

Performance data published in this brochure has been developed from field testing, customer field reports and/or in-house testing.

While the utmost care has been used in compiling this brochure, we assume no responsibility for errors. Specifications subject to change without notice. This edition cancels all previous issues. Subject to change without notice.

Gasket Factors "M" and "Y"

"M" and "Y" data are to be used for flange designs only as specified in the ASME Boiler and Pressure Vessel Code Division 1, Section VIII, Appendix 2. They are not meant to be used as gasket seating stress values in actual service. Our bolt torque tables give that information and should be used as such.

"M" - Maintenance Factor

A factor that provides the additional preload needed in the flange fasteners to maintain the compressive load on a gasket after internal pressure is applied to a joint.









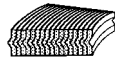

$$M = (W - A_2P) / A_1P$$

Where: W = Total Fastener force (lb. or N)
 A_2 = Inside area of gasket (in.² or mm²)
 P = Test pressure (psig or N/mm²)
 A_1 = Gasket area (in.² or mm²)

"Y" - Minimum Design Seating Stress

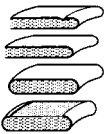
The minimum compressive stress in pounds per square inch (or bar) on the contact area of the gasket that is required to provide a seal at an internal pressure of 2 psig (0.14 bar).

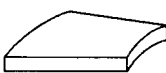
$$Y = W / A_1$$

Gasket Design	Gasket Material	Gasket Factor "M"	Min. Design Seating Stress "Y" psi	
Spiral wound metal, graphite or PTFE filled	 Stainless Steel or MONEL®	3.00	10,000	
Garlock CONTROLLED DENSITY® flexible graphite filled spiral wound	 Stainless Steel or MONEL®	3.00	7,500	
Garlock EDGE®	 Stainless Steel or MONEL®	2.00	5,000	
Garlock GRAPHONIC®	 Stainless Steel and flexible graphite	2.00 (1/16")	2,000 (1/16")	
		9.00 (1/8")	3,000 (1/8")	
	Liquid service:	2.00	900	
Kammprofile™ gasket	 Stainless steel core Flexible graphite facing	4.00	1,000*	
Corrugated metal, non-asbestos or corrugated metal-jacketed, non-asbestos filled	 Soft aluminum	2.50	2,900	
		Soft copper or brass	2.75	3,700
		Iron or soft steel	3.00	4,500
		MONEL® or 4%-6% chrome	3.25	5,500
		Stainless Steel	3.50	6,500
Corrugated metal	 Soft aluminum	2.75	3,700	
		Soft copper or brass	3.00	4,500
		Iron or soft steel	3.25	5,500
		MONEL® or 4%-6% chrome	3.50	6,500
		Stainless Steel	3.75	7,600
Flat metal-jacketed, non-asbestos filled	 Soft aluminum	3.25	5,500	
		Soft copper or brass	3.50	6,500
		Iron or soft steel	3.75	7,600
		MONEL®	3.50	8,000
		4%-6% chrome	3.75	9,000
Stainless Steel	3.75	9,000		
KAMMPROFILE	 Soft aluminum	3.25	5,500	
		Soft copper or brass	3.50	6,500
		Iron or soft steel	3.75	7,600
		MONEL® or 4%-6% chrome	3.75	9,000
		Stainless Steel	4.25	10,100
Solid flat metal	 Soft aluminum	4.00	8,800	
		Soft copper or brass	4.75	13,000
		Iron or soft steel	5.50	18,000
		MONEL® or 4%-6% chrome	6.00	21,800
		Stainless Steel	6.50	26,000
Ring joint	 Iron or soft steel	5.50	18,000	
		MONEL® or 4%-6% chrome	6.00	21,800
		Stainless steel	6.50	26,000

This table lists many commonly used gasket materials and contact facings with suggested design values of "M" and "Y" that generally have proven satisfactory in actual service when using effective gasket seating width B_1 described in the formula on page 35. The design values and other details given in this table are suggested only and are not mandatory.

MONEL® is a registered trademark of International Nickel.

NOTE:

When designing a flange, a "Y" value of 4,000 psi is suggested.

Selection of Metals

The chemical resistance of gaskets be governed by their materials of construction. The selection is generally based on chemical resistance, heat resistance and cost. The most popular metals include:

- » Mild Steel
- » Stainless Steel 304
- » Stainless Steel 316
- » INCONEL® 600*
- » Nickle 200
- » HASTELLOY C® 276†
- » MONEL® 400‡
- » INCONEL® 625*
- » INCOLOY® 825*

The selection of a metal to be used in a gasket that is suitably resistant to corrosive media or to high temperature involves many considerations. Garlock recommends that designers contact the manufacturers of alloyed material, who conduct laboratory corrosive tests and in-plant corrosion testing.

CONCENTRATION OF CORROSIVE AGENTS

Dilute solutions are not necessarily less corrosive than those of full strength, and the reverse is often the case. Probably the most familiar example of this is the action of sulfuric acid on iron; concentrations over 90% acid may be handled by iron without much difficulty, but below this concentration, the rate of attack will increase rapidly with an increase in dilution.

PURITY OF CORROSIVE AGENTS

Purity, in this instance, means the absence of contaminating amounts of other corrosive compounds. For example, the corrosive attack by compounds that are derivatives of an acid: in the pure state these compounds may be relatively inert, but if contaminated by any carry-over of free acid they must be handled more carefully.

TEMPERATURE

Besides its effects upon the mechanical properties of the gasket, the temperature of the corrosive agent will have a marked influence upon the rate of attack.

FORMS OF CORROSION

- » General corrosion
- » Galvanic corrosion
- » Concentration cell or crevice corrosion
- » Chemical pitting
- » Intergranular corrosion
- » Effects of stress on corrosion
 - › Corrosion fatigue
 - › Stress corrosion cracking

CORROSIVE ENVIRONMENTS

- » Atmospheric corrosion
- » Corrosion by water, acids
- » Corrosion by alkalis, salts, fluorine
- » Corrosion by chlorines and hydrogen
- » Corrosion by chlorides

* INCONEL® and INCOLOY® are registered trademarks of Inco Alloys International, Inc.

† HASTELLOY® C is a registered trademark of Haynes International.

‡ MONEL® is a registered trademark of International Nickel.



Flange Rotation

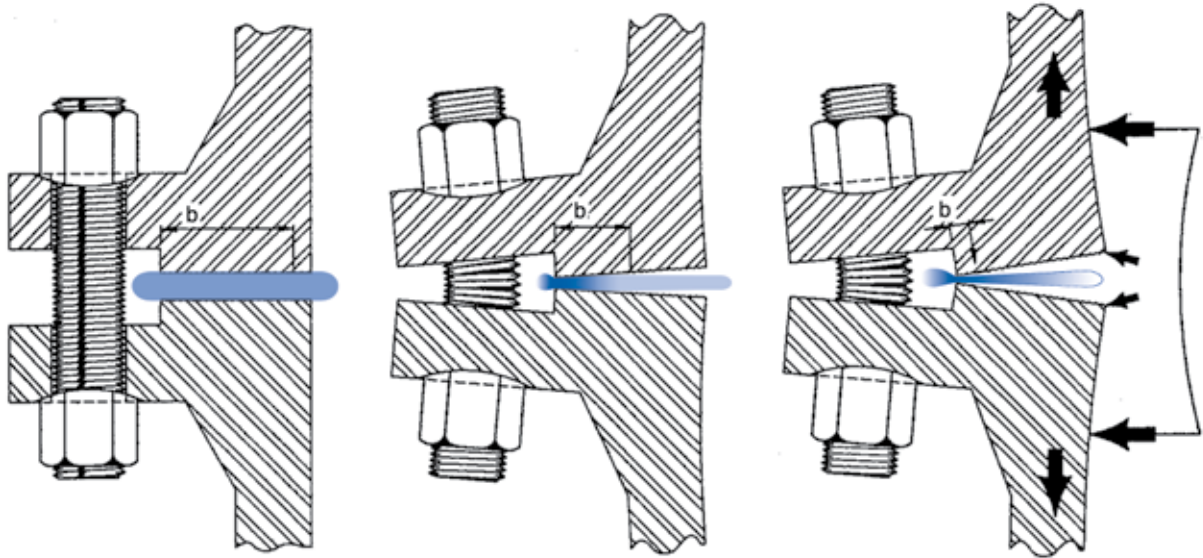

WHAT IS FLANGE ROTATION?

A common problem in the pressure vessel and piping world is the phenomenon called flange rotation. It is usually encountered under bolt tightening with a raised face flange. The outer edges of a raised face flange are pulled towards each other when the bolts are tightened, and relieved towards the inside of the vessel or pipe. See illustration.

HOW MUCH FLANGE ROTATION?

Petrochemical engineers who must cope with rotation say that it can greatly increase the difficulties of sealing a joint. Some even say that rotations as small as 0.10 degrees can make a tight seal almost impossible. This is quite a bit stiffer than the preliminary proposed ASME limit of a maximum 0.30 degrees for integral type flanges or 0.20 degrees for loose type flanges.

FLANGE ROTATION AND THE CODE

Flange rotation is known to be important but there are no simple ways to estimate it. Section VIII of the ASME Code, Table UA-49.2 Effective Gasket Width acknowledges rotation by introducing an effective width for a gasket, which is equal to or less than half the width of the gasket or joint-contact-surface seating width. This allowance leakage assumes that at least half of the gasket will have been unloaded by rotation. But flanges often rotate more or less than this. Proper installation and bolt tightening procedures greatly reduce the chance for flange rotation.

EXCESSIVE BOLT LOAD

One of the causes of flange rotation is excessive bolt load. In fact, too much bolt load can rotate raised face flanges enough to open a leak path. The threat of rotation, therefore, can place an upper limit on planned or specific clamping force.

WARNING:

Properties/applications shown throughout this brochure are typical. Your specific application should not be under taken without independent study and evaluation for suitability. For specific application recommendations consult Garlock. Failure to select the proper sealing products could result in property damage and/or serious personal injury.

Performance data published in this brochure has been developed from field testing, customer field reports and/or in-house testing.

While the utmost care has been used in compiling this brochure, we assume no responsibility for errors. Specifications subject to change without notice. This edition cancels all previous issues. Subject to change without notice.

Gasket Installation

In a flanged connection, all components must be selected and installed correctly to achieve a seal. The most common cause of leaky gasketed joints is improper installation procedures.

BOLTING PROCEDURES

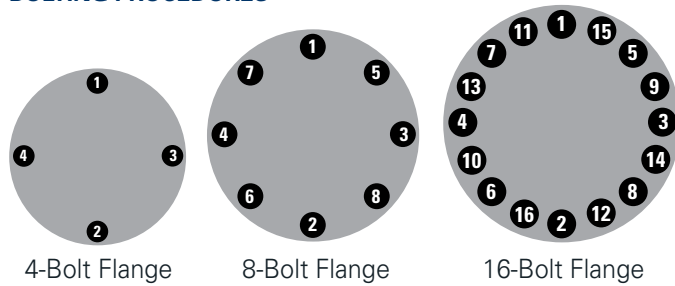

All applicable safety standards including lockout / tag out procedures should be practiced.

- » Clean and inspect flange surfaces.
- » Place the gasket on the flange surface to be sealed.
- » Bring the opposing flange into contact with the gasket.
- » Bolts or studs must be new or in as-new condition. Clean the threads and lubricate them with a quality lubricant, such as an oil and graphite mixture.
- » Place the bolts/studs into the bolt holes.
- » Finger-tighten the nuts.
- » Follow a crossing bolting sequence similar to what is shown in the diagrams above.
- » During the initial tightening sequence, do not tighten any bolts/studs more than 30% of the final desired torque. Doing so will cause the flange to tip and the gasket will not be evenly compressed.
- » Upon reaching the desired torque, do a circular bolt-to-bolt torque check to make certain that all bolts/studs are at the desired final torque.
- » When possible, bolts/studs should be retorqued 12-24 hours after initial installation after observing all lockout / tag out procedures.
- » Due to creep and stress relaxation, it is essential to prestress the bolts to ensure adequate stress load during operation.

Torque Tables

These tables were developed to be used with Garlock metallic gaskets. They are to be used only as a general guide. They should not be considered to contain absolute values due to the large number of uncontrollable variables involved with bolted joints.

All bolt torque values are based upon the use of new nuts (ASTM A194, GR 2H) and new bolts (ASTM A193, GR B7) of proper design, acceptable quality and approved materials of construction as well as metallurgy. It is also recommended that two hardened steel washers be used under the head of each nut or turning surface (if tightening the bolt) and that a thread lubricant (i.e. oil and graphite) be used on the nuts, bolts and washers.

The flanges are assumed to be in good condition and in compliance with ASME B16.5 or B16.47 specifications. Special attention should be given to seating surface finish and flatness.

Only torque wrenches that have been calibrated should be used. The proper bolt tightening pattern must be followed with the desired ultimate torque value arrived at in a minimum of three incremental steps. For example: (30 ft. lbs., 60 ft. lbs., 100 ft. lbs.) All bolts in the flange should then be checked in consecutive bolt-to-bolt order. The torque values are based on actual contact dimension, which will vary depending on the gasket type.

No provisions have been made in these tables to account for vibration effects on the bolts. These tables are based on ambient conditions, without compensation for elevated temperatures.

WARNING:

Properties/applications shown throughout this brochure are typical. Your specific application should not be undertaken without independent study and evaluation for suitability. For specific application recommendations consult Garlock. Failure to select the proper sealing products could result in property damage and/or serious personal injury.

Performance data published in this brochure has been developed from field testing, customer field reports and/or in-house testing.

While the utmost care has been used in compiling this brochure, we assume no responsibility for errors. Specifications subject to change without notice. This edition cancels all previous issues. Subject to change without notice.

Torque Tables

150# RAISED FACE FLANGES			FLEXSEAL®		EDGE®		Kammprofile		CMG*		Jacketed Gasket	
Nominal Pipe Size (inches)	Number of Bolts	Size of Bolts	Minimum Torque (ft.lbs)	Preferred Torque (ft.lbs)	Minimum Torque (ft.lbs)	Preferred Torque (ft.lbs)	Minimum Torque (ft.lbs)	Preferred Torque (ft.lbs)	Minimum Torque (ft.lbs)	Preferred Torque (ft.lbs)	Minimum Torque (ft.lbs)	Preferred Torque (ft.lbs)
0.50	4	0.50	16	47	9	52	8	42	11	37	18	53
0.75	4	0.50	22	60	12	60	11	54	16	60	25	60
1	4	0.50	30	60	15	60	13	60	21	60	27	60
1.25	4	0.50	33	60	16	60	24	60	33	60	42	60
1.5	4	0.50	47	60	23	60	31	60	43	60	59	60
2	4	0.63	74	120	36	120	55	120	87	120	94	120
2.5	4	0.63	87	120	43	120	63	120	101	120	108	120
3	4	0.63	120	120	63	120	102	120	120	120	120	120
4	8	0.63	92	120	47	120	76	120	105	120	111	120
5	8	0.75	124	200	63	200	106	200	146	200	189	200
6	8	0.75	178	200	89	200	137	200	185	200	173	200
8	8	0.75	200	200	128	200	190	200	250	200	200	200
10	12	0.88	236	320	120	320	178	320	235	320	300	320
12	12	0.88	320	320	163	320	178	320	312	320	320	320
14	12	1.00	408	490	209	490	268	490	396	490	451	490
16	16	1.00	421	490	210	490	267	490	377	490	449	490
18	16	1.13	649	710	328	710	381	710	560	710	562	710
20	20	1.13	572	710	289	710	335	710	494	710	562	710
24	20	1.25	820	1000	415	1000	438	1000	704	1000	740	1000

*Includes GRAPHONIC®, G.E.T™ and TEPHONIC™

Based on ASTM A193 B7 bolts - 60,000 psi maximum bolt stress

300# RAISED FACE FLANGES			FLEXSEAL®		EDGE®		Kammprofile		CMG*		Jacketed Gasket	
Nominal Pipe Size (inches)	Number of Bolts	Size of Bolts	Minimum Torque (ft.lbs)	Preferred Torque (ft.lbs)	Minimum Torque (ft.lbs)	Preferred Torque (ft.lbs)	Minimum Torque (ft.lbs)	Preferred Torque (ft.lbs)	Minimum Torque (ft.lbs)	Preferred Torque (ft.lbs)	Minimum Torque (ft.lbs)	Preferred Torque (ft.lbs)
0.50	4	0.50	16	47	9	52	8	42	11	37	18	53
0.75	4	0.63	28	84	15	88	14	68	20	67	31	92
1	4	0.63	38	114	19	115	17	84	27	89	34	102
1.25	4	0.63	41	120	20	120	30	120	41	120	53	120
1.5	4	0.75	66	198	32	191	43	200	60	200	81	200
2	8	0.63	37	112	18	109	27	120	43	120	47	120
2.5	8	0.75	48	145	24	144	35	177	56	188	60	180
3	8	0.75	71	200	35	200	57	200	83	200	75	200
4	8	0.75	103	200	52	200	84	200	117	200	123	200
5	8	0.75	124	200	63	200	106	200	146	200	189	200
6	12	0.75	118	200	60	200	92	200	123	200	116	200
8	12	0.88	194	320	98	320	146	320	192	320	207	320
10	16	1.00	206	490	105	490	155	490	205	490	262	490
12	16	1.13	309	710	156	710	171	710	299	710	341	710
14	20	1.13	269	710	138	710	177	710	261	710	297	710
16	20	1.25	399	1000	203	1000	259	1000	365	1000	435	1000
18	24	1.25	478	1000	241	1000	280	1000	412	1000	414	1000
20	24	1.25	526	1000	266	1000	308	1000	454	1000	517	1000
24	24	1.50	723	1600	366	1600	386	1600	621	1600	652	1600

*Includes GRAPHONIC®, G.E.T™ and TEPHONIC™

Based on ASTM A193 B7 bolts - 60,000 psi maximum bolt stress

Torque Tables

400# RAISED FACE FLANGES			FLEXSEAL®		EDGE®		Kammprofile		CMG*		Jacketed Gasket	
Nominal Pipe Size (inches)	Number of Bolts	Size of Bolts	Minimum Torque (ft.lbs)	Preferred Torque (ft.lbs)	Minimum Torque (ft.lbs)	Preferred Torque (ft.lbs)	Minimum Torque (ft.lbs)	Preferred Torque (ft.lbs)	Minimum Torque (ft.lbs)	Preferred Torque (ft.lbs)	Minimum Torque (ft.lbs)	Preferred Torque (ft.lbs)
0.50	4	0.50	16	47	17	52	8	42	Contact Engineering		18	53
0.75	4	0.63	28	84	29	88	14	68			31	92
1	4	0.63	38	114	38	115	17	84			34	102
1.25	4	0.63	41	120	40	120	30	120			53	120
1.5	4	0.75	66	198	64	191	43	200			81	200
2	8	0.63	37	112	36	109	27	120			47	120
2.5	8	0.75	48	145	48	144	35	177			60	180
3	8	0.75	71	200	71	200	57	200			75	200
4	8	0.88	149	320	120	320	97	320			142	320
5	8	0.88	190	320	146	320	123	320			218	320
6	12	0.88	173	320	138	320	106	320			133	320
8	12	1.00	280	490	22-	490	170	490			241	490
10	16	1.13	314	710	230	691	170	710			287	710
12	16	1.25	456	1000	345	1000	188	941			376	1000
14	20	1.25	373	1000	304	911	195	975			328	983
16	20	1.38	532	1630	445	1335	283	1360			475	1360
18	24	1.38	567	1360	527	1360	306	1360			452	1357
20	24	1.50	604	1600	563	1600	326	1600			547	1600
24	24	1.75	962	2887	975	2924	513	2566			868	2603

*Includes GRAPHONIC®, G.E.T™ and TEPHONIC™

Based on ASTM A193 B7 bolts - 60,000 psi maximum bolt stress

600# RAISED FACE FLANGES			FLEXSEAL®		EDGE®		Kammprofile		CMG*		Jacketed Gasket	
Nominal Pipe Size (inches)	Number of Bolts	Size of Bolts	Minimum Torque (ft.lbs)	Preferred Torque (ft.lbs)	Minimum Torque (ft.lbs)	Preferred Torque (ft.lbs)	Minimum Torque (ft.lbs)	Preferred Torque (ft.lbs)	Minimum Torque (ft.lbs)	Preferred Torque (ft.lbs)	Minimum Torque (ft.lbs)	Preferred Torque (ft.lbs)
0.50	4	0.50	16	47	17	52	8	42	Contact Engineering		18	53
0.75	4	0.63	28	84	29	88	14	68			31	92
1	4	0.63	38	114	38	115	17	84			34	102
1.25	4	0.63	41	120	40	120	30	120			53	120
1.5	4	0.75	66	198	64	191	43	200			81	200
2	8	0.63	37	112	36	109	27	120			47	120
2.5	8	0.75	48	145	48	144	35	177			60	180
3	8	0.75	71	200	71	200	57	200			75	200
4	8	0.88	149	320	120	320	97	320			142	320
5	8	1.00	221	490	170	490	143	490			254	490
6	12	1.00	202	490	160	480	123	490			155	466
8	12	1.13	307	710	241	710	187	710			264	710
10	16	1.25	346	1000	254	763	188	938			317	951
12	20	1.25	365	1000	276	829	151	753			301	904
14	20	1.38	408	1224	332	996	213	1066			358	1075
16	20	1.50	514	1543	430	1291	274	1370			460	1379
18	20	1.63	757	2200	704	2112	409	2044			604	1811
20	24	1.63	695	2085	647	1941	375	1875			629	1886
24	24	1.88	1103	3308	1117	3350	588	2940			994	2983

*Includes GRAPHONIC®, G.E.T™ and TEPHONIC™

Based on ASTM A193 B7 bolts - 60,000 psi maximum bolt stress

Torque Tables

900# RAISED FACE FLANGES			FLEXSEAL®		EDGE®		Kammprofile		CMG*		Jacketed Gasket	
Nominal Pipe Size (inches)	Number of Bolts	Size of Bolts	Minimum Torque (ft.lbs)	Preferred Torque (ft.lbs)	Minimum Torque (ft.lbs)	Preferred Torque (ft.lbs)	Minimum Torque (ft.lbs)	Preferred Torque (ft.lbs)	Minimum Torque (ft.lbs)	Preferred Torque (ft.lbs)	Minimum Torque (ft.lbs)	Preferred Torque (ft.lbs)
0.50	4	0.75	22	100	24	100	12	100	Contact Engineering		24	73
0.75	4	0.75	31	100	33	100	15	100			34	103
1	4	0.88	49	160	49	160	22	160			44	131
1.25	4	0.88	53	160	52	160	39	193			68	204
1.5	4	1.00	89	266	85	256	58	289			109	328
2	8	0.88	48	160	47	160	35	176			60	180
2.5	8	1.00	65	245	65	245	47	245			81	242
3	8	0.88	106	319	81	244	66	328			87	260
4	8	1.13	191	572	153	458	124	622			182	545
5	8	1.25	268	804	206	617	173	865			307	921
6	12	1.13	221	664	176	527	135	675			170	511
8	12	1.38	333	1000	303	909	225	1127			319	956
10	16	1.38	306	919	278	835	205	1026			347	1040
12	20	1.38	368	1103	302	907	165	824			329	988
14	20	1.50	388	1164	321	963	206	1031			347	1040
16	20	1.63	514	1541	495	1485	315	1575			529	1586
18	20	1.88	991	2972	933	2800	542	2710			800	2401
20	20	2.00	934	2802	984	2952	540	2850			956	2867
24	20	2.50	1382	4400	1582	4747	833	4400			1409	4227

*Includes GRAPHONIC®, G.E.T™ and TEPHONIC™

Based on ASTM A193 B7 bolts - 60,000 psi maximum bolt stress

1500# RAISED FACE FLANGES			FLEXSEAL®		EDGE®		Kammprofile		CMG*		Jacketed Gasket	
Nominal Pipe Size (inches)	Number of Bolts	Size of Bolts	Minimum Torque (ft.lbs)	Preferred Torque (ft.lbs)	Minimum Torque (ft.lbs)	Preferred Torque (ft.lbs)	Minimum Torque (ft.lbs)	Preferred Torque (ft.lbs)	Minimum Torque (ft.lbs)	Preferred Torque (ft.lbs)	Minimum Torque (ft.lbs)	Preferred Torque (ft.lbs)
0.50	4	0.75	22	100	24	100	20	100	Contact Engineering		24	73
0.75	4	0.75	31	100	33	100	25	100			34	103
1	4	0.88	49	160	49	160	36	160			44	131
1.25	4	0.88	80	240	52	160	64	193			68	204
1.5	4	1.00	118	353	85	256	96	289			109	328
2	8	0.88	76	227	47	160	59	176			60	180
2.5	8	1.00	108	325	65	245	79	245			81	242
3	8	1.13	150	451	104	355	140	419			111	332
4	8	1.25	231	694	169	506	229	686			200	601
5	8	1.50	323	970	218	800	305	915			325	975
6	12	1.38	289	867	212	680	272	815			206	617
8	12	1.63	432	1297	337	1100	418	1253			354	1063
10	12	1.88	754	2262	547	2000	673	2018			682	2045
12	16	2.00	647	2200	532	2200	484	2200			580	1741
14	16	2.25	684	3180	655	3180	701	3180			707	2121
16	16	2.50	1141	4400	969	4400	1027	4400			1035	3104
18	16	2.75	1606	5920	1513	5920	1464	5920			1297	3892
20	16	3.00	1921	7720	1810	7720	1748	7720			1758	5273
24	16	3.50	3100	13000	2867	13000	2516	13000			2553	7658

*Includes GRAPHONIC®, G.E.T™ and TEPHONIC™

Based on ASTM A193 B7 bolts - 60,000 psi maximum bolt stress

Torque Tables

2500# RAISED FACE FLANGES			FLEXSEAL®		EDGE®		Kammprofile		CMG*		Jacketed Gasket	
Nominal Pipe Size (inches)	Number of Bolts	Size of Bolts	Minimum Torque (ft.lbs)	Preferred Torque (ft.lbs)	Minimum Torque (ft.lbs)	Preferred Torque (ft.lbs)	Minimum Torque (ft.lbs)	Preferred Torque (ft.lbs)	Minimum Torque (ft.lbs)	Preferred Torque (ft.lbs)	Minimum Torque (ft.lbs)	Preferred Torque (ft.lbs)
0.50	4	0.75	22	100	24	100	20	100	Contact Engineering		24	73
0.75	4	0.75	31	100	33	100	25	100			34	103
1	4	0.88	49	160	49	160	36	160			44	131
1.25	4	1.00	93	279	60	245	75	245			79	237
1.5	4	1.13	129	387	94	355	106	355			120	360
2	8	1.00	88	264	55	245	68	245			70	210
2.5	8	1.13	119	357	71	355	87	355			89	266
3	8	1.25	166	500	115	500	154	500			122	367
4	8	1.50	245	800	178	800	242	800			212	636
5	8	1.75	430	1500	289	1500	406	1500			432	1297
6	8	2.00	611	2200	448	2200	574	2200			434	1303
8	12	2.00	548	2200	427	2200	529	2200			449	1347
10	12	2.50	831	4400	646	4400	794	4400			805	2415
12	12	2.75	1326	5920	963	5920	875	5920		1050	3150	

*Includes GRAPHONIC®, G.E.T™ and TEPHONIC™

Based on ASTM A193 B7 bolts - 60,000 psi maximum bolt stress

WARNING:

Properties/applications shown throughout this brochure are typical. Your specific application should not be undertaken without independent study and evaluation for suitability. For specific application recommendations consult Garlock. Failure to select the proper sealing products could result in property damage and/or serious personal injury.

Performance data published in this brochure has been developed from field testing, customer field reports and/or in-house testing.

While the utmost care has been used in compiling this brochure, we assume no responsibility for errors. Specifications subject to change without notice. This edition cancels all previous issues. Subject to change without notice.

Torque to Stress Studs/Bolts

The torque required to produce a certain stress in bolting is dependent on several conditions, including:

- » Bolt diameter and thread pitch
- » Condition of nut bearing or turning surfaces
- » Lubrication of threads and nut bearing surfaces.

The tables below reflect the results of many tests to determine the relation between torque and bolt stress. Values are based on steel studs/bolts that have been well-lubricated with a heavy graphite and oil mixture.

A non-lubricated stud/bolt has an efficiency of about 50% of a well-lubricated bolt. Also, different lubricants produce results that vary from 50% to 100% of the tabulated stress figures.

FOR ALLOY STEEL STUD BOLTS (LOAD IN POUNDS ON STUD BOLTS WHEN TORQUE LOAD IS APPLIED) (UN8)*

Nominal Diameter of Bolt (inches)	Number of Threads (per inch)	Diameter at Root of Thread (inches)	Area at Root of Thread (sq. inch)	Stress					
				30,000 psi		45,000 psi		60,000 psi	
				Torque (ft lbs)	Compression (lbs)	Torque (ft lbs)	Compression (lbs)	Torque (ft lbs)	Compression (lbs)
1/4	20	0.185	0.027	4	810	6	1,215	8	1,620
5/16	18	0.240	0.045	8	1,350	12	2,025	16	2,700
3/8	16	0.294	0.068	12	2,040	18	3,060	24	4,080
7/16	14	0.345	0.093	20	2,790	30	4,185	40	5,580
1/2	13	0.400	0.126	30	3,780	45	5,670	60	7,560
9/16	12	0.454	0.162	45	4,860	68	7,290	90	9,720
5/8	11	0.507	0.202	60	6,060	90	9,090	120	12,120
3/4	10	0.620	0.302	100	9,060	150	13,590	200	18,120
7/8	9	0.731	0.419	160	12,570	240	18,855	320	25,140
1	8	0.838	0.551	245	16,530	368	24,795	490	33,060
1-1/8	8	0.963	0.728	355	21,840	533	32,760	710	43,680
1-1/4	8	1.088	0.929	500	27,870	750	41,805	1,000	55,740
1-3/8	8	1.213	1.155	680	34,650	1,020	51,975	1,360	69,300
1-1/2	8	1.338	1.405	800	42,150	1,200	63,225	1,600	84,300
1-5/8	8	1.463	1.680	1,100	50,400	1,650	75,600	2,200	100,800
1-3/4	8	1.588	1.980	1,500	59,400	2,250	89,100	3,000	118,800
1-7/8	8	1.713	2.304	2,000	69,120	3,000	103,680	4,000	138,240
2	8	1.838	2.652	2,200	79,560	3,300	119,340	4,400	159,120
2-1/4	8	2.088	3.423	3,180	102,690	4,770	154,035	6,360	205,380
2-1/2	8	2.338	4.292	4,400	128,760	6,600	193,140	8,800	257,520
2-3/4	8	2.588	5.259	5,920	157,770	8,880	236,655	11,840	315,540
3	8	2.838	6.324	7,720	189,720	11,580	264,580	15,440	379,440

FOR MACHINE BOLTS AND COLD ROLLED STEEL STUD BOLTS (LOAD IN POUNDS ON STUD BOLTS WHEN TORQUE LOAD IS APPLIED) (UNC)

Nominal Diameter of Bolt (inches)	Number of Threads (per inch)	Diameter at Root of Thread (inches)	Area at Root of Thread (sq. inch)	Stress					
				7,500 psi		15,000 psi		30,000 psi	
				Torque (ft lbs)	Compression (lbs)	Torque (ft lbs)	Compression (lbs)	Torque (ft lbs)	Compression (lbs)
1/4	20	0.185	0.027	1	203	2	405	4	810
5/16	18	0.240	0.045	2	338	4	675	8	1,350
3/8	16	0.294	0.068	3	510	6	1,020	12	2,040
7/16	14	0.345	0.093	5	698	10	1,395	20	2,790
1/2	13	0.400	0.126	8	945	15	1,890	30	3,780
9/16	12	0.454	0.162	12	1,215	23	2,340	45	4,860
5/8	11	0.507	0.202	15	1,515	30	3,030	60	6,060
3/4	10	0.620	0.302	25	2,265	50	4,530	100	9,060
7/8	9	0.731	0.419	40	3,143	80	6,285	160	12,570
1	8	0.838	0.551	62	4,133	123	8,265	245	16,530
1-1/8	7	0.969	0.693	98	5,190	195	10,380	390	20,760
1-1/4	7	1.064	0.890	137	6,675	273	13,350	545	26,700
1-3/8	6	1.158	1.054	183	7,905	365	15,810	730	31,620
1-1/2	6	1.283	1.294	219	9,705	437	19,410	875	38,820
1-5/8	5-1/2	1.389	1.515	300	11,363	600	22,725	1,200	45,450
1-3/4	5	1.490	1.744	390	13,080	775	26,160	1,550	52,320
1-7/8	5	1.615	2.049	525	15,368	1,050	30,735	2,100	61,470
2	4-1/2	1.711	2.300	563	17,250	1,125	34,500	2,250	69,000

* UN8 (8 thread series) is the standard for ASTM A193 B7, A193 B8, B8M and A320 bolts and studs

Troubleshooting Leaking Joints

One of the best methods for determining the cause of joint leakage is the careful examination of the gasket where the leakage occurred.

Observation	Possible Remedies
Gasket badly corroded	» Select replacement material with improved corrosion resistance
Gasket extruded excessively	» Select replacement material with better cold flow properties » Select replacement material with better load capacity - i.e., more dense
Gasket grossly crushed	» Select replacement material with better load carrying capacity » Provide means to prevent crushing the gasket by use of a stop ring or redesign of flanges
Gasket mechanically damaged due to overhang of raised face or flange bore	» Review gasket dimensions to insure gaskets are proper size » Make certain gaskets are properly centered in joint
No apparent gasket compression achieved	» Select softer gasket material » Select thicker gasket material » Reduce gasket area to allow higher unit seating load
Gasket substantially thinner on OD than ID due to excessive flange rotation or bending	» Alter gasket dimensions to move gasket reaction closer to bolts to minimize bending movement » Provide stiffness to flange by means of back-up rings » Select softer gasket material to lower required seating stresses » Reduce gasket area to lower seating stresses
Gasket unevenly compressed around circumference	» Make certain proper sequential bolt-up procedures are followed » Ensure flanges are properly aligned
Gasket thickness varies periodically around circumference	» Provide reinforcing rings for flanges to better distribute bolt load » Select gasket material with lower seating stress » Provide additional bolts if possible to obtain better load distribution » If flanges are warped, remachine or use softer gasket material

Ordering Guide

RW, RWI SPIRAL WOUND

When ordering, specify:

- » Nominal pipe size or gasket dimensions, and pressure class
- » Winding and filler materials
- » Centering and/or inner compression ring material

SW, SWI SPIRAL WOUND

When ordering, specify:

- » OD and ID dimensions (and tolerance, if other than standard—see page 22)
- » Thickness of gasket
- » Winding and filler material
- » Inner ring material, if required (Style SWI)
- » Pressure rating

HH AND MCR MANHOLE

When ordering, specify:

- » Make and model of boiler and/or equipment if available (See chart page 11)
- » Gasket style and configuration
- » Dimensions of gasket (thickness, flange seating width, and shape)
- » Maximum operating pressure and temperature
- » Type of metal and filler materials

CUSTOM GASKETS

A spiral wound gasket can be made to almost any dimension required. Possible designs include multiple windings and rings, with combinations of different fillers or special winding materials and ring shapes. Describe your application or send us a drawing and we'll help you design the appropriate winding.

HEAT EXCHANGER

The size restrictions for heat exchanger gaskets depend only on the available sizes of the materials. Heat exchanger gaskets are commonly made in diameters up to 120", with rib widths up to 1-1/4" and thicknesses up to 1/4".

When ordering, specify:

- » Style number
- » Shape (Give configuration code, page 21)
- » Thickness
- » Material (metal or metal and filler)

Plus specify (according to diagram below):

1. Outside diameter
2. Inside diameter
3. Rib width
4. Radii on ribs, at rib intersect points and around bolt holes
5. Bolt circle diameter
6. Distance from center line of gasket to center line of ribs
7. Size and number of bolt holes
8. Hole placement relative to center line of gasket

NOTE:

In addition to the above information, drawings of your application are always helpful in proper dimensioning of gaskets.

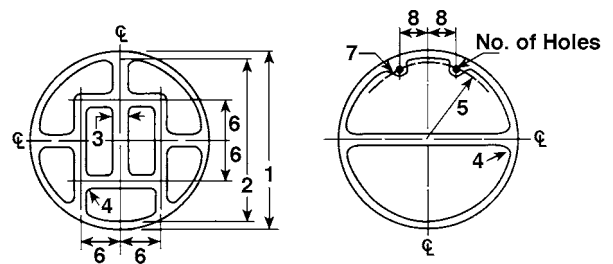

WARNING:

Properties/applications shown throughout this brochure are typical. Your specific application should not be undertaken without independent study and evaluation for suitability. For specific application recommendations consult Garlock. Failure to select the proper sealing products could result in property damage and/or serious personal injury.

Performance data published in this brochure has been developed from field testing, customer field reports and/or in-house testing.

While the utmost care has been used in compiling this brochure, we assume no responsibility for errors. Specifications subject to change without notice. This edition cancels all previous issues. Subject to change without notice.

Application Data Form

Date: _____

From: _____

For: Garlock Metallic Gasket Engineering

Title: _____

Email: gasketapps@garlock.com

Company: _____

Page: 1 of

Address: _____

Drawing attached Yes No

Fax Number: _____

Phone Number: _____

Email Address: _____

APPLICATION

- Pipe Flange
- Heat Exchanger
- Manway
- Compressor

- Pumps - centrifugal / horizontal split case
- Flue Duct
- Valve Bonnet
- Other _____

SERVICE CONDITIONS

Maximum Temperature _____ °F/°C

Continuous Operating Temperature _____ °F/°C

Internal Pressure _____ psig/bar

PSIG / bar Continuous Intermittent

Thermal Cycling _____ /24 hours

Vibration Yes No

Other (specify) _____

BOLTS

Grade _____

Diameter _____

Length _____

Number _____

CHEMICAL COMPATIBILITY

Media _____

pH _____

Concentration _____

Liquid or Gas _____

FLANGE

Standard

Material _____

Non-Standard

Material _____

Size _____ Rating _____

I.D. / O.D. _____

Surface Finish _____ RMS

Flange Thickness _____

Phonographic Concentric

Bolt Circle Diameter _____

Face (raised, flat, tongue & groove, etc.) _____

Surface Finish _____ RMS

Phonographic Concentric

Face (raised, flat, tongue & groove, etc.) _____

Comments: _____

Conversions

COMMON ABBREVIATIONS

SI - International Metric Standard	kgf - kilogram force
Pa - Pascal	N - Newton
psi - pounds per square inch	in - inch
psig - pounds per square inch guage	ft - foot
oz - ounce	yd - yard
g - gram	m - meter
lbf - pound force	gal - gallon
	l - liter

PREFIXES

M (mega)	= 1,000,000	= 10 ⁶
k (kilo)	= 1,000	= 10 ³
c (centi)	= 0.01	= 10 ⁻²
m (milli)	= 0.001	= 10 ⁻³
u (micro)	= 0.000001	= 10 ⁻⁶

METRIC CONVERSIONS

Conversion from:	To SI units:	Multiply by:
Length		
mil	mm	0.0254
in	mm	25.4
in	cm	2.54
ft	m	0.3048
yd	m	0.9144
Weight		
oz	g	28.35
oz	kg	0.0283
lb	g	453.6
lb	kg	0.4536
lb	N	4.4482
Force		
lbf	N	4.448
kgf	N	9.8066
Area		
in ²	cm ²	6.4516
ft ²	m ²	0.0929
Pressure		
bar	psi	14.5
psi	Pa	6895
psi	kPa	6.89
psi	bar	0.069
psi	MPa	0.0069
N/m ²	Pa	1.00
N/mm ²	MPa	1.00
Torque		
in-lb	Nm	0.113
ft/lb	Nm	1.3558
Density		
oz/in ³	g/cm ³	1.73
g/cm ³	kg/m ³	1000
lb/ft ³	kg/m ³	16.02
lb/ft ³	g/cm ³	0.01602
Adhesion		
lb/in	kN.m	0.1751
Volume		
gal	l	3.7854
gal	m ³	0.0038

GARLOCK

an *EnPro* Industries family of companies

Tel: 1-877-GARLOCK / 315.597.4811

Fax: 800.543.0598 / 315.597.3216

www.garlock.com

Garlock

GPT

Garlock Australia

Garlock de Canada, LTD

Garlock China

Garlock Singapore

Garlock Germany

Garlock India Private Limited

Garlock de Mexico, S.A. De C.V.

Garlock New Zealand

Garlock Great Britain Limited

Garlock Middle East